

***TM 55-1905-223-24-7**

TECHNICAL MANUAL

**UNIT, INTERMEDIATE DIRECT
SUPPORT
AND INTERMEDIATE GENERAL
SUPPORT
MAINTENANCE INSTRUCTIONS**

WASTE HEAT EVAPORATOR (WHE)

**FOR
LANDING CRAFT UTILITY (LCU)
NSN 1905-01-154-1191**

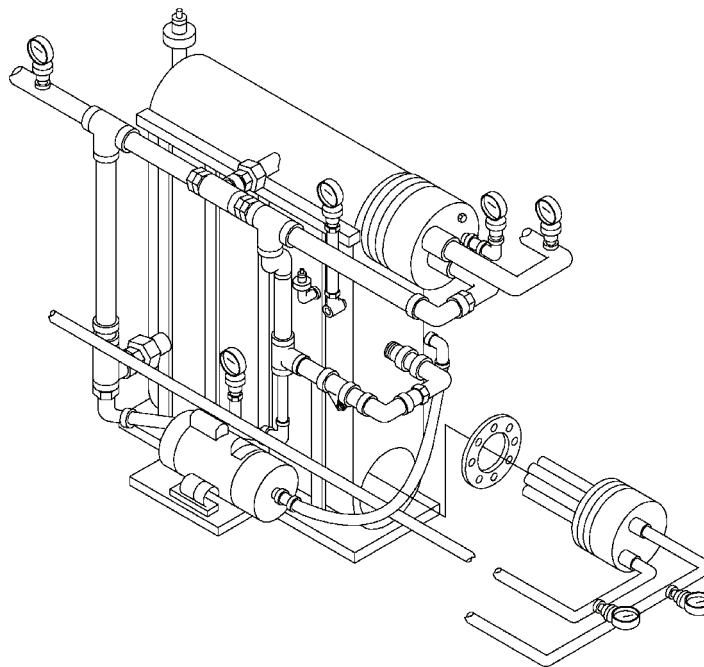

*Supersedes TM 55-1905-223-24-7, 17 January 1989, including all changes.

DISTRIBUTION STATEMENT A: Approved for public release, distribution is unlimited.

HEADQUARTERS, DEPARTMENT OF THE ARMY

FEBRUARY 2008

WARNING SUMMARY

MODIFICATION HAZARD

Unauthorized modifications, alterations or installations of or to this equipment are prohibited and are in violation of AR 750-10. Any such unauthorized modifications, alterations or installations could result in death, injury or damage to the equipment.

MOVING MACHINERY HAZARDS

Be very careful when operating or working near moving machinery.

Running engines, rotating shafts and other moving machinery parts could cause personal injury or death. Before maintenance is performed on motor driven equipment, the main circuit breaker should be de-energized and labeled "OUT OF SERVICE." Only authorized maintenance personnel should make repairs to this equipment.

ELECTRICAL HAZARDS

Whenever possible, the power supply to the equipment must be shut off before beginning work on the equipment.

Do not be misled by the term "low voltage." Potentials as low as 50 volts may cause death under adverse conditions.

Be careful not to contact 115-VAC input connections when installing or operating this equipment.

Whenever the nature of the operation permits, keep one hand away from the equipment to reduce the hazard of current flowing through the body.

CHEMICAL HAZARD WARNING

The chemical feed system contains hazardous treatment chemicals that can cause severe burns. Avoid contact with skin. Use protective gloves and safety goggles when working on or around the chemical feed system.

DO NOT REPAIR OR ADJUST ALONE

Under no circumstances should repair or adjustment of energized equipment be attempted alone. The immediate presence of someone capable of rendering aid is required. Before making adjustments, be sure to protect against grounding. If possible, adjustments should be made with one hand, with the other hand free and clear of equipment. Even when power has been removed from equipment circuits, dangerous potentials may still exist due to retention of charges by capacitors. Circuits must be grounded and all capacitors discharged prior to attempting repairs.

TEST EQUIPMENT

Make certain test equipment is in good condition. If a test meter must be held, ground the case of the meter before starting measurements. Do not touch live equipment or personnel working on live equipment while holding a test meter. Some types of measuring devices should not be grounded; such devices should not be held when taking measurements.

INTERLOCKS

Interlocks are provided for safety of personnel and equipment and should be used only for the purpose intended. They should not be battle-shortened or otherwise modified except by authorized maintenance personnel. Do not depend solely upon interlocks for protection. Whenever possible, disconnect power at power distribution source.

For Artificial Respiration, refer to FM 4-25.11.

LIST OF EFFECTIVE PAGES

NOTE: *Supersedes TM 55-1904-223-24-7, 17 January 1989, including all changes. Zero in the "Change No." column indicates an original page.

Date of issue for revision is: 08 February 2008

TOTAL NUMBER OF PAGES IS 144 CONSISTING OF THE FOLLOWING:

Page No.	*Change No.	Page No.	*Change No.
Cover	0	A-1/(A-2 blank)	0
a/(b blank).....	0	B-1 through B-5/(B-6 blank).....	0
i and ii	0	C-1 and C-2	0
1-1 through 1-15/(1-16 blank)	0	D-1 and D-2	0
2-1 through 2-82.....	0	Glossary-1 and Glossary-2.....	0
3-1 through 3-6.....	0	Index-1 and Index-2.....	0
4-1/(4-2 blank)	0	DA 2028.....	0
		Metric/PIN.....	0

*Zero in this column indicates an original page.

**UNIT, INTERMEDIATE DIRECT SUPPORT AND
INTERMEDIATE GENERAL SUPPORT
MAINTENANCE INSTRUCTIONS**

**WASTE HEAT EVAPORATOR
FOR
LANDING CRAFT UTILITY (LCU)
NSN 1905-01-154-1191**

REPORTING ERRORS AND RECOMMENDING IMPROVEMENTS

You can help improve this publication. If you find any mistakes or if you know of a way to improve the procedures, please let us know. Submit your DA Form 2028 (Recommended Changes to Equipment Technical Publications) through the Internet, on the Army Electronic Product Support (AEPS) website. The Internet address is <https://aeeps.ria.army.mil>. The DA Form 2028 is located under the Public Applications section in the AEPS Public Home Page. Fill out the form and click on SUBMIT. Using this form on the AEPS will enable us to respond quicker to your comments and better manage the DA Form 2028 program. You may also mail, fax or e-mail your letter or DA Form 2028 direct to: TACOM Life Cycle Management Command, ATTN: AMSTA-LC-LMPP / TECH PUBS, 1 Rock Island Arsenal, Rock Island, IL 61299-7630. The e-mail address is ROCK-TACOM-TECH-PUBS@conus.army.mil. The fax number is DSN 793-0726 or Commercial (309) 782-0726.

DISTRIBUTION STATEMENT A: Approved for public release; distribution is unlimited.

TABLE OF CONTENTS

	<u>PAGE</u>
CHAPTER 1 INTRODUCTION	1-1
Section I General Information	1-1
Section II Equipment Description and Data	1-1
Section III Principles of Operation	1-14
CHAPTER 2 UNIT MAINTENANCE INSTRUCTIONS	2-1
Section I Repair Parts; Special Tools; Test, Measurement, and Diagnostic Equipment (TMDE); and Support Equipment	2-1
Section II Service Upon Receipt	2-1
Section III Unit Preventive Maintenance Checks and Services (PMCS)	2-8
Section IV Unit Maintenance Troubleshooting Procedures	2-11
Section V Unit Maintenance Procedures	2-18
Section VI Preparation for Storage or Shipment	2-82
CHAPTER 3 INTERMEDIATE DIRECT SUPPORT MAINTENANCE INSTRUCTIONS.....	3-1
Section I Repair Parts, Special Tools; Test, Measurement and Diagnostic Equipment (TMDE); and Support Equipment	3-1
Section II Service Upon Receipt	3-1
Section III Intermediate Direct Support Preventive Maintenance Checks and Services (PMCS)	3-2

*Supersedes TM 55-1905-223-24-7, 17 January 1989, including all Changes.

TABLE OF CONTENTS - Continued

	<u>PAGE</u>
CHAPTER 3	INTERMEDIATE DIRECT SUPPORT MAINTENANCE INSTRUCTIONS (cont)
Section IV	Intermediate Direct Support Troubleshooting 3-2
Section V	Intermediate Direct Support Maintenance Procedures..... 3-2
Section VI	Preparation for Storage or Shipment..... 3-6
CHAPTER 4	INTERMEDIATE GENERAL SUPPORT MAINTENANCE INSTRUCTIONS..... 4-1
APPENDIX A	REFERENCES A-1
APPENDIX B	MAINTENANCE ALLOCATION CHART B-1
APPENDIX C	EXPANDABLE/DURABLE SUPPLIES AND MATERIALS LIST C-1
APPENDIX D	TORQUE VALUES D-1
GLOSSARY	ABBREVIATIONS AND DEFINITIONS Glossary-1
ALPHABETICAL INDEX Index-1

**CHAPTER 1
INTRODUCTION**

	<u>Page</u>
Section I. General Information	1-1
Section II. Equipment Description and Data	1-1
Section III. Principles of Operation.....	1-14

SECTION I. GENERAL INFORMATION

1-1. Scope. The scope of this manual is as follows:

- a. Type of Manual. Unit, intermediate direct support, and intermediate general support maintenance instructions.
- b. Model Number and Equipment Name. HJ20C Waste Heat Evaporator, installed aboard the LCU 2000 Class watercraft.
- c. Purpose of Equipment. The Waste Heat Evaporator converts seawater into potable water.

1-2. Maintenance Forms, Records, and Reports. Department of the Army forms and procedures used for equipment maintenance are those prescribed by DA PAM 750-8, The Army Maintenance Management System (TAMMS) Users Manual.

1-3. Destruction of Army Materiel. Refer to TM 750-244-3 for instructions covering the destruction of Army materiel to prevent enemy use.

1-4. Reporting Equipment Improvement Recommendations (EIR). If your Waste Heat Evaporator (WHE) needs improvement, let us know. Send us an EIR. You, the user, are the only one who can tell us what you don't like about your equipment. Let us know why you don't like the design or performance. If you have Internet access, the easiest and fastest way to report problems or suggestions is to go to <https://aeps.ria.army.mil/aepspublic.cfm> (scroll down and choose to submit an Equipment Improvement Recommendation [EIR], a Product Quality Deficiency Report [PQDR] or a Warranty Claim Action [WCA]). You may also submit your information using an SF 368 (Product Quality Deficiency Report). You can send your SF 368 via e-mail, regular mail, or facsimile using the addresses/facsimile numbers specified in DA PAM 750-8, The Army Maintenance Management System (TAMMS) Users Manual. We will send you a reply.

1-5. Preparation for Storage or Shipment. Administrative storage of equipment issued to and used by Army activities will have preventive maintenance performed in accordance with the Preventive Maintenance Checks and Services (PMCS) charts before storing. When removing the equipment from administrative storage, the PMCS should be performed to assure operational readiness. Repacking of equipment for shipment or storage is covered in Paragraph 2-27.

SECTION II. EQUIPMENT DESCRIPTION AND DATA

1-6. Characteristics, Capabilities, and Features. A very broad view of the Waste Heat Evaporator is as follows:

- a. Characteristics.
 - (1) Distills seawater to freshwater, through principles of distillation (Paragraph 1-10).
- b. Capabilities and Features.
 - (1) Produces up to 1,200 gallons of freshwater per day.

- (2) Water produced contains less than 4 parts per million (ppm) of total dissolved solids (0.25 grains of sea salt per gallon).

1-7. Location and Description of Major Components.

1-7.1 System Water Locations And Definitions.

Two identical Evaporator units (Figure 1-1) are located one over the other in the engine room on the port side of the centerline aft. Piping systems provide for seawater supply, jacket water supply, brine overboard discharge, and product water transfer to the freshwater storage tanks (1, Figure 1-1). Nominal output from each waste heat Evaporator is 1,200 gallons per day (GPD). System water locations and definitions are as follows:

- a. Freshwater (FW), normally located between the ultraviolet (UV) sterilizer and the pressure set tanks. FW and potable water are sometimes used interchangeably within this manual and in the LCU Operator's Manual, TM 55-1905-223-10.
- b. Potable Water, normally located from the pressure set tanks to point of use. Potable water is freshwater which has been tested and deemed fit for human consumption.
- c. Distillate or product water, located between the Evaporator trough and distillate freshwater pump.
- d. Product Water, located between the distillate freshwater pump and UV sterilizer.
- e. Condensate, located on the upper shell of the Evaporator, collecting in the distillate trough.
- f. Seawater (SW), also known as raw water, is from the sea and contains salts in quantities above safe levels for human consumption.
- g. Jacket Water (JW), located between the keel coolers, ballast coolers, or outlet side of the seawater heaters in the Evaporators to the engines.
- h. Hot Jacket Water (HJW), located between engine thermostat to keel coolers, ballast coolers, or seawater heaters in the Evaporators.
- i. Brine, located between the brine jet suction in the lower half of the Evaporator to the overboard discharge. Brine is seawater with a high level of dissolved solids.

1-7.2 System Component Location and Description.

System flow and major component identification are shown in Figure 1-1. Monitoring and control components test the salinity of the product water and energize the distillate dump valve to save or dump the water as appropriate. Other control components include on off controls, valves, flow meters, and pressure gauges. Components are illustrated in Figures 1-3 through 1-5 and described as follows:

- a. Evaporator Unit. The Waste Heat Evaporator (1, Figure 1-1), located aft in the engine room at the bottom of the entrance ladder, is a submerged tube thermal circulation type, that is, the seawater heater tube (1, Figure 1-2) through which the heat is circulated is submerged in the seawater being boiled. The welded rectangular Evaporator shell is constructed of copper-nickel alloy to provide maximum corrosion resistance. The seawater heater is fabricated from 90-10 copper-nickel material approved for marine service. All material, with the exception of the external bracing, is fabricated from nonferrous metals. Seawater flooding the outside of the seawater heater tube picks up the heat, raising the seawater temperature to the evaporation point at low atmospheric pressure (vacuum). The shell vacuum is created by excess seawater being routed through a brine jet pump (10, Figure 1-4) and vacuum jet pump (3 Figure 1-4). Condensation occurs in the upper shell area around the freshwater condenser tube (5, Figure 1-4). Condensate falls into a trough where the distillate freshwater pump (6, Figure 1-3) draws suction. The distillate freshwater pump pushes the product water through an ultraviolet sterilizer (5, Figure 1-3) to the freshwater storage tanks. The Evaporator may be chemically cleaned while distilling freshwater without harm to the product (distilled) water.
 - (1) Brine Jet Pump. The brine jet pump (10, Figure 1-4) uses excess seawater feed (17 GPM) to extract the brine accumulation from the bottom of the Evaporator. The brine is removed at a rate of

1.2 gallons per minute (GPM) at 136.5 °F and is replaced by a new supply of seawater at 2 GPM at 109.5 °F. The brine jet pump works in parallel with the vacuum jet pump to provide optimum performance.

- (2) Seawater Feed Orifice. The seawater feed orifice (8, Figure 1-4) restricts seawater feed into the Evaporator to 2 GPM at 109.5 °F by reducing volume and pressure. This decreased flow allows the seawater to pick up heat from the seawater heater tube, and the reduced pressure controls the low pressure of the Evaporator.
- (3) Distillate Dump Valve. The distillate dump valve (2, Figure 1-3) redirects product water overboard when the preset alarm point is sensed by the salinity cell. This prevents the freshwater tanks from becoming contaminated by high salinity water. A warning indicator located on the Engineering Operating Station (EOS) control console (Figure 1-5) illuminates when product water is dumping overboard.
- (4) Auxiliary Seawater Pump. The auxiliary seawater (ASW) pump (Figure 1-1) draws seawater from the sea chest, through a strainer, and discharges to the seawater feed valve (SW-44, Figure 1-1), seawater feed orifice (8, Figure 1-4), freshwater condensing tube (5, Figure 1-4), and brine and vacuum jet pumps (10 and 3, Figure 1-4). Output volume to the waste heat Evaporator from the auxiliary seawater pump is 36 GPM at 85°F and 45 psig. Power to the ASW pump is supplied by the MCC located in the EOS (Figure 1-7).
- (5) Distillate Pump. The distillate pump (6, Figure 1-3) draws the distillate water from the trough in the upper shell of the Evaporator, and pushes the freshwater through a UV sterilizer to port and starboard freshwater tanks. Power to the distillate pump is supplied by the MCC 227 power panel (Figure 1-6).
- (6) Seawater Pressure Gauge. The seawater pressure gauge (6, Figure 1-4) is essential for monitoring the operation of the waste heat Evaporator. Design pressure of 45 psig is critical to the overall output of the Evaporator. This pressure is required to keep both the brine and vacuum jet pumps operating properly.
- (7) Evaporator Sight Glass. The Evaporator sight glass (9, Figure 1-4) is triangular shaped, and is located high enough so that scaling, flooding, and overall interior condition may be observed in the seawater feed area and seawater heater tube.
- (8) Ultraviolet Sterilizer. The UV sterilizer (5, Figure 1-3) aids in disinfecting the product water prior to its entering the freshwater tanks. This component is required to meet safe operation in brackish water, in polluted sea ports, and during initial startup where bacterial carryover during evaporation could contaminate the entire freshwater system.
- (9) Freshwater Condenser. The freshwater condenser (5, Figure 1-4) is a tube bundle located in the upper half of the Evaporator shell. Seawater is fed from the auxiliary seawater feed pump through the freshwater condenser to aid in condensing the evaporated seawater. The seawater exits the condenser tube and is routed to the brine and vacuum jet pumps, and to the Evaporator feed orifice.
- (10) Freshwater Storage Tanks. Two freshwater storage tanks (Figure 1-1) are located in the forward part of the engine room.
- (11) Seawater Heater. The seawater heater tube is the lower tube bundle in the Evaporator (1, Figure 1-2). Hot jacket water from the main engines flows through the seawater heater and back. The heat from the jacket water evaporates the feed seawater within the Evaporator shell.
- (12) Vacuum Jet Pump. The vacuum jet pump (3, Figure 1-4) removes air within the Evaporator using the venturi principle of a jet pump. Excess seawater (17 GPM) is used to remove the air from the Evaporator shell.
- (13) Vacuum Release Valve. The vacuum release valve (11, Figure 1-4) allows the operator to break the vacuum seal should problems occur within the waste heat Evaporator.

- (14) Distillate and Jacket Water Power Panel. The distillate and jacket water panel (Figure 1-6) controls electrical power to No. 1 and No. 2 Evaporator distillate pump (2 and 3, Figure 1-6) and the No. 1 and No. 2 Evaporator jacket water pumps (1 and 4, Figure 1-6).
- (15) Auxiliary Seawater (ASW) Pump Controller. The auxiliary seawater pump controller controls the operation of the seawater pump with Start (1, Figure 1-7) and Stop (4) push buttons. Operation of the pump is displayed by Motor Run Indicator (2) and Motor Stop Indicator (3). In the event of a casualty and electrical trip, the pump has the capability to operate in Emergency Run (5) mode and an electrical Reset (6).
- b. Chemical Injection System. The chemical injection system provides the required quantity of cleaning chemicals used during normal operation. This system includes a mixing pump and motor (eductor type) suction line throttled by use of a needle valve. The chemical injection system is located on top of the chemical cleaning tanks (2, Figure 1-1).
 - (1) Chemical Cleaning Tanks. The chemical cleaning tanks (2, Figure 1-1) are used for measuring Evaporator cleaning chemicals which continually clean the Evaporator during operation. The chemical cleaning tanks are typically located in the forward port side of the engine room against the aft bulkhead of the port freshwater storage tank (Figure 1-1).
 - (2) Chemical Agitator. The chemical agitator is located on top of the chemical tanks, and is used to prevent separation of the chemical and water in the tanks, maintaining a constant ratio.
- c. Salinity Control System. The salinity control system is typically located aft in engine room on port side (may be on stanchion forward of the Evaporator). The system continually monitors the distillate product output, maintaining the produced water contains less than 4 parts per million (ppm) of total dissolved solids. Figure 1-9 displays the electrical diagram of the salinity system.
 - (1) Salinity Power Panel. The salinity power panel (1, Figure 1-1) controls the operation of the salinity cell and the distillate dump valve. Normal operation of the power panel is indicated by the orange indicator. The meter indicates the level of sea salt in the product. When the salinity cell indicates a higher PPG level the red and blue alarm lights will illuminate. Refer to Figure 1-8 and Table 1-1 for a detailed view.
 - (2) Salinity Cell. The salinity cell (8, Figure 1-3) ensures the distillate product is less then 0.25 grains of sea salt per gallon (GPG) of water. When the level is greater then 0.25 GPG the salinity power panel opens the distillate dump valve, discharging the high level water overboard.

1-8. Equipment Data. The following is the general equipment data for the Evaporator unit and all associated components.

<u>Characteristics</u>	<u>Reference Data</u>
<u>Waste Heat Evaporator</u>	
Model	HJ20C, Beaird Industries
Product Water Production	50 GPH at 85°F
Product Water Quality	<0.25 Grains Sea Salt Per Gallon
Construction	90/10 Shell/Tube
Power Requirements	220 VAC/60 Hz, 3-Phase
Operating Current (at 220 VAC)	13.0 Amperes
Operating Vacuum	26 to 27 in Hg
Weight	410 lb (185.9 kg)
Operating Temperatures	(Evaporation) 115°F (46°C) to 140°F (60°C)
Evaporator Dimensions	L=41-1/2" W=22-1/4" H=30-1/2"
<u>Auxiliary Seawater Pump</u>	
Model	ZCH2 3X2.5
Maximum Feed Pressure	45 psig
Maximum Capacity	36 GPM at 85°F
Maximum Speed	3,500 rpm
Weight	295 lbs

1-9. Safety, Care, and Handling. Safety precautions must be observed at all times while performing maintenance. General WARNINGS and first-aid data appear in the front of this manual. Review all safety information before starting any task. Carefully read through an entire maintenance procedure before performing any maintenance function. Make sure the task can be done safely. All WARNINGS, CAUTIONS, and NOTES are of great importance to your safety and the safety of the equipment.

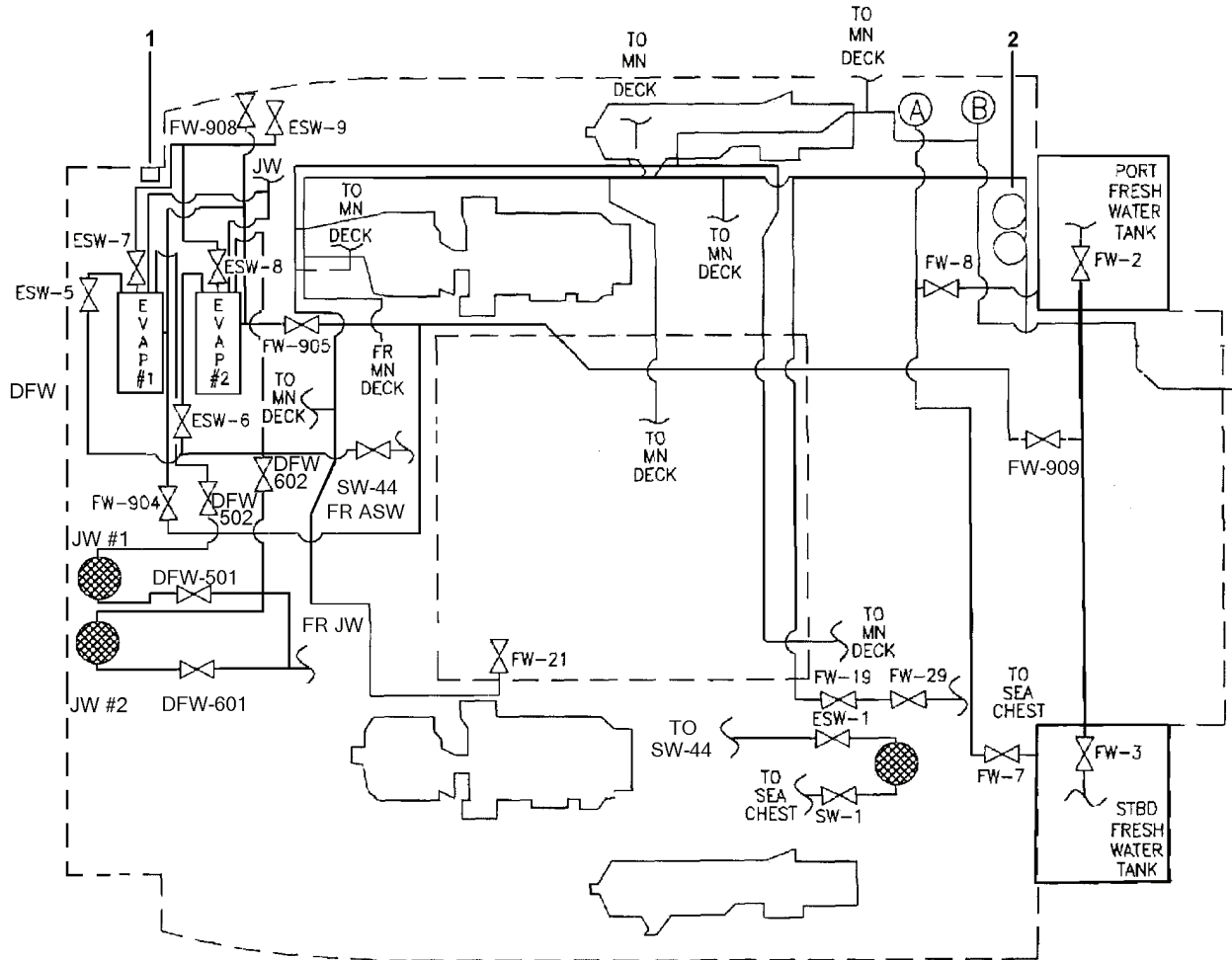

Figure 1-1. Waste Heat Evaporator, System Location.

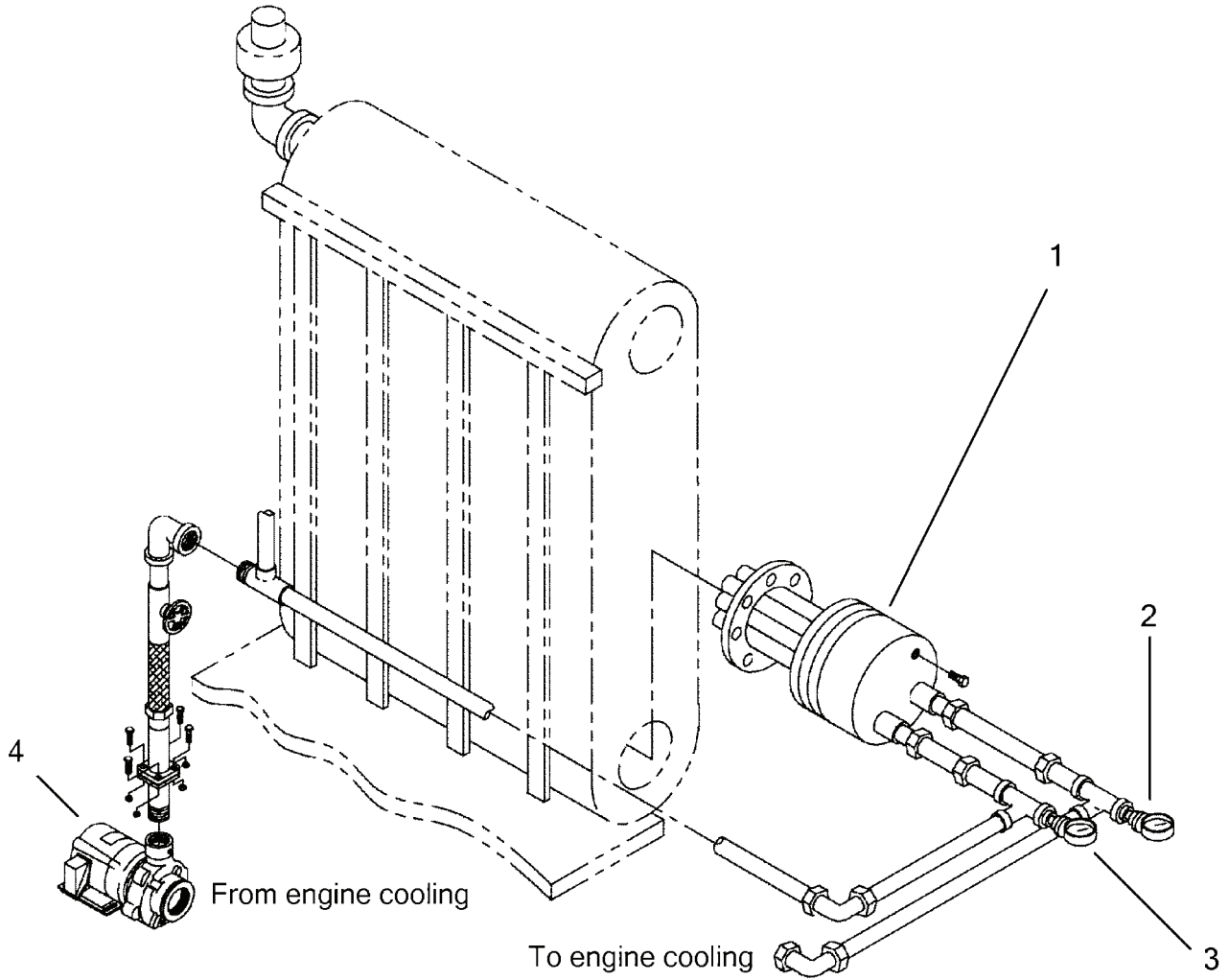

Figure 1-2. Waste Heat Evaporator Jacket Water Piping.

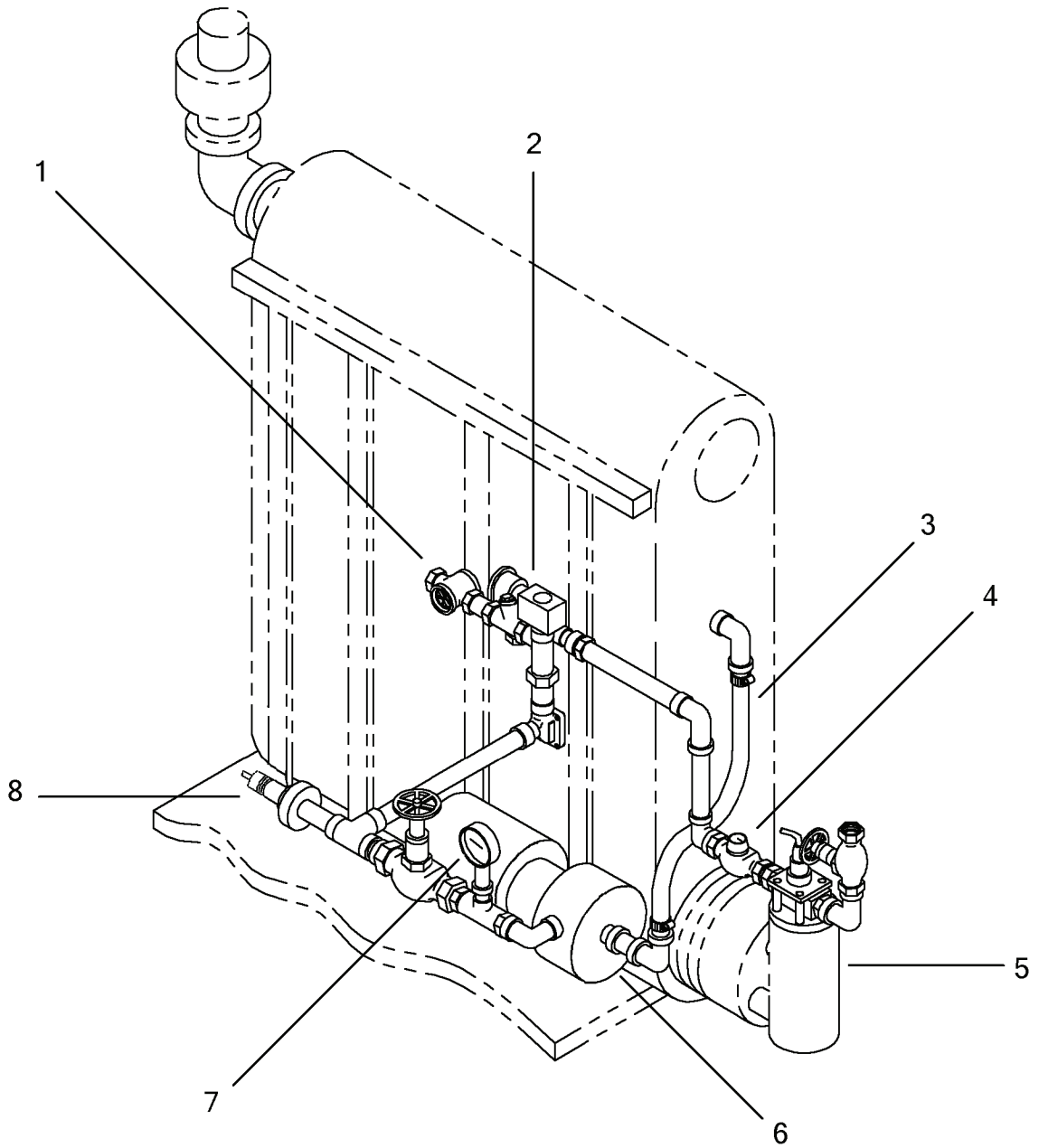

Figure 1-3. Waste Heat Evaporator Distillate Piping Group.

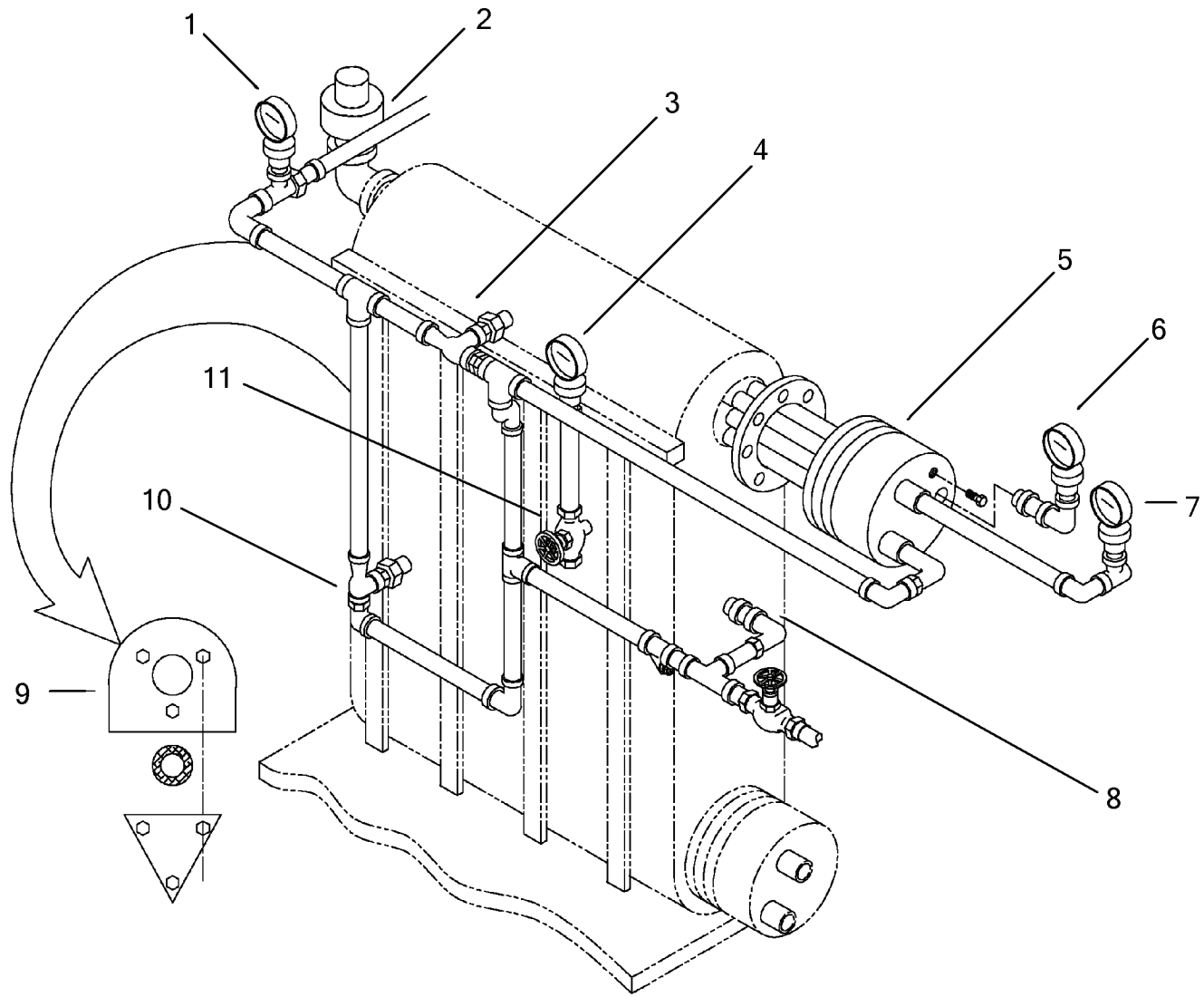

Figure 1-4. Waste Heat Evaporator Feed Water Piping Group.

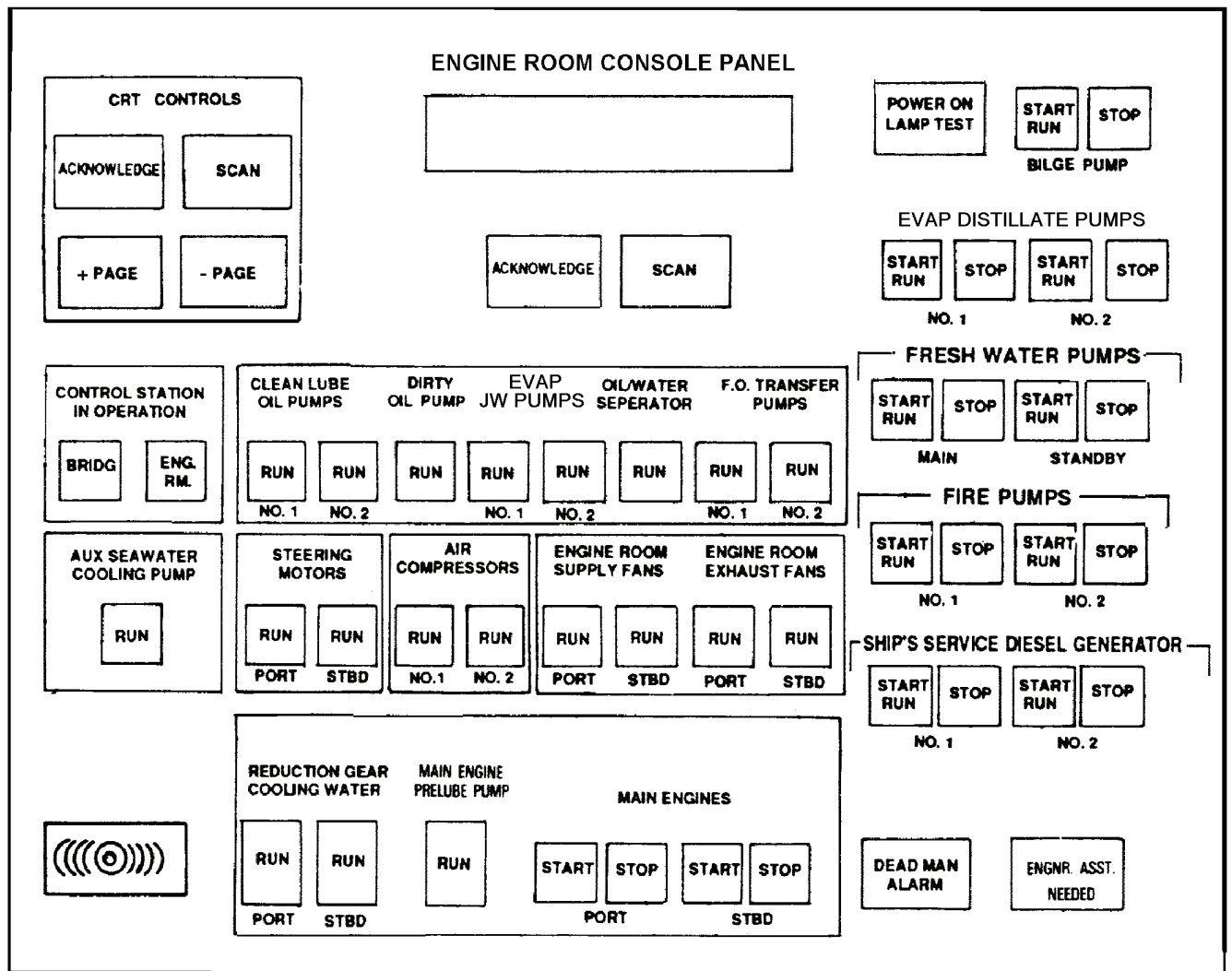

Figure 1-5. Engineering Operating Station Control Console.

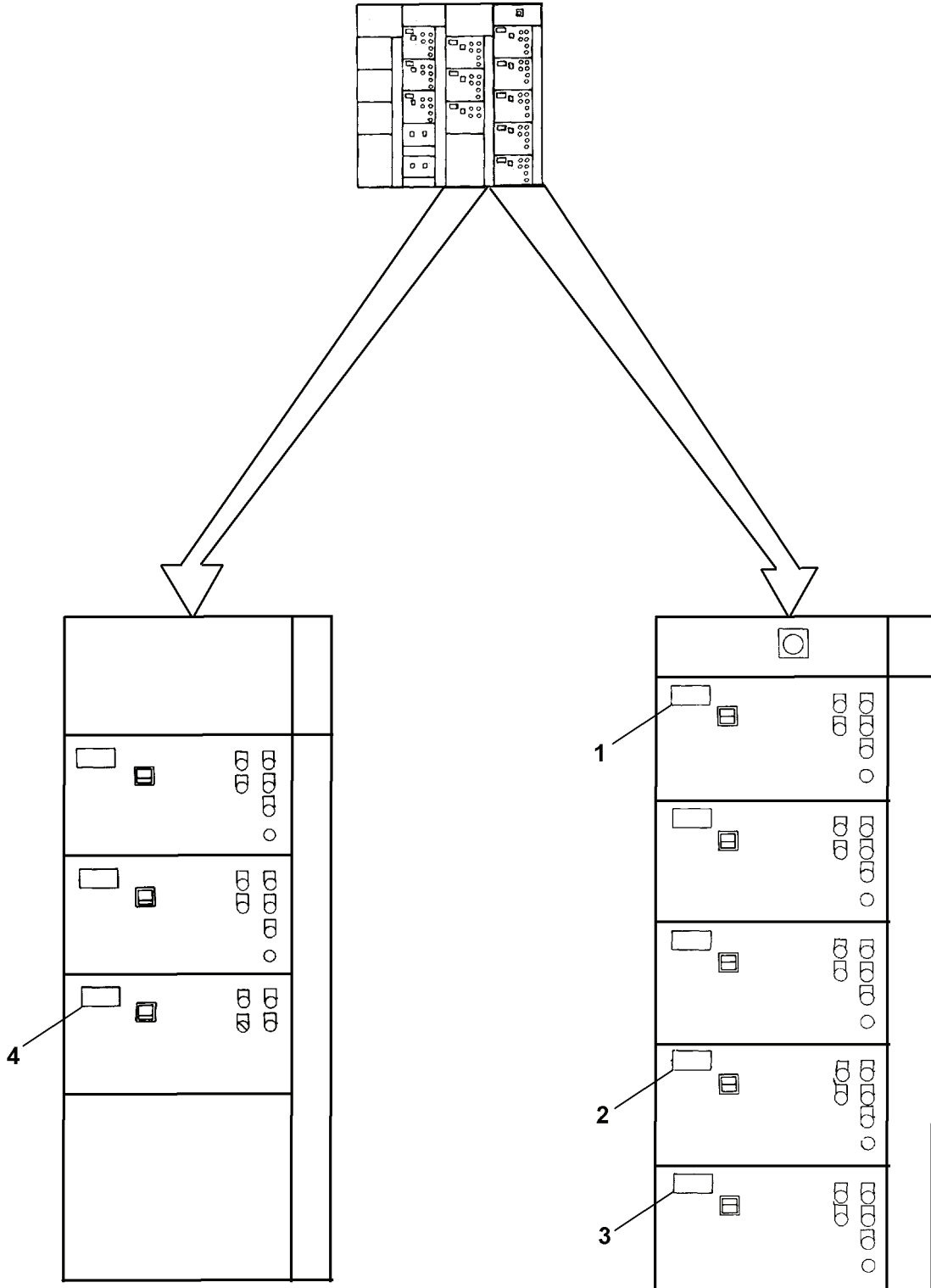

Figure 1-6 Distillate and Jacket Water Feed Power Panel.

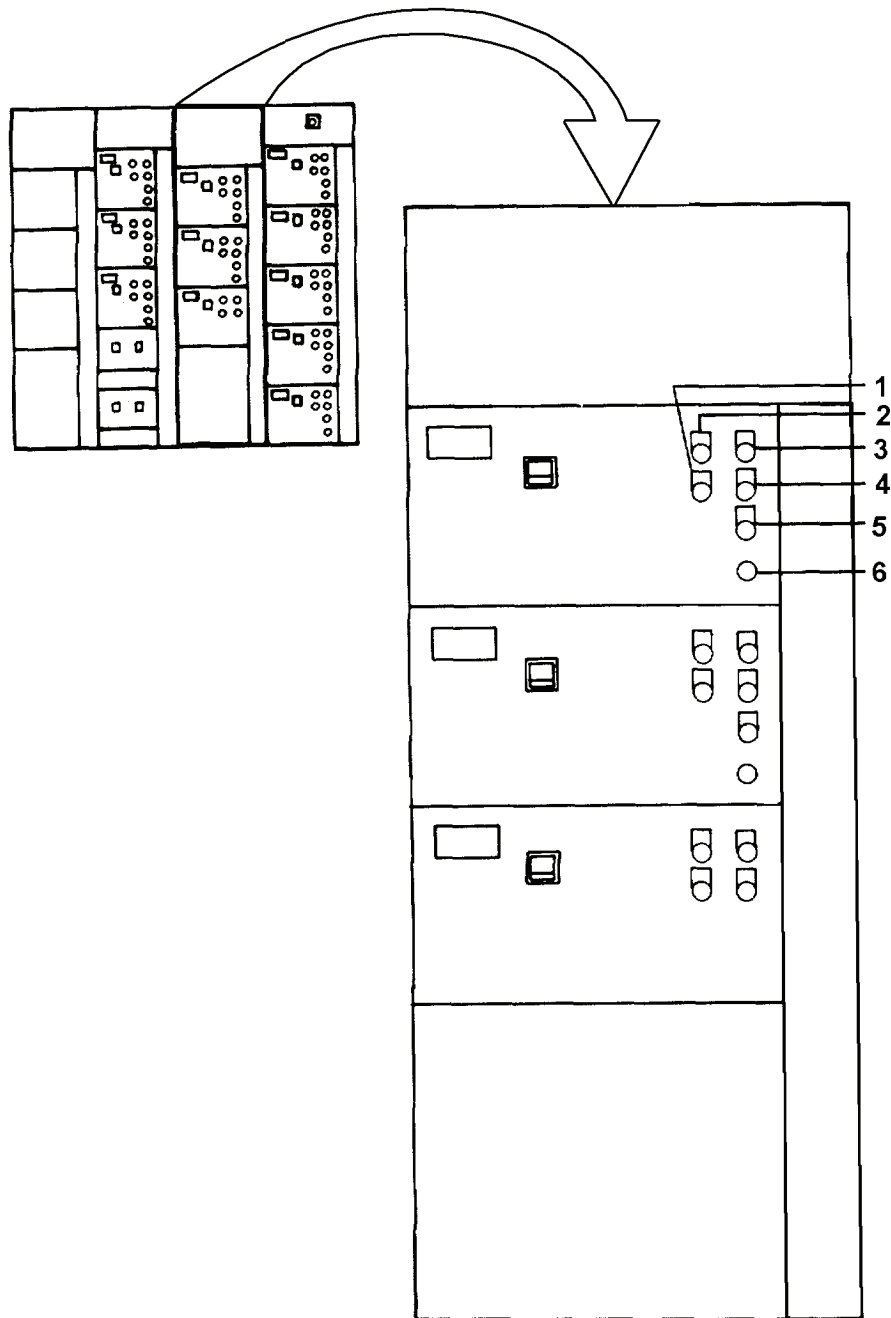

Figure 1-7. Auxiliary Seawater (ASW) Pump Controller.

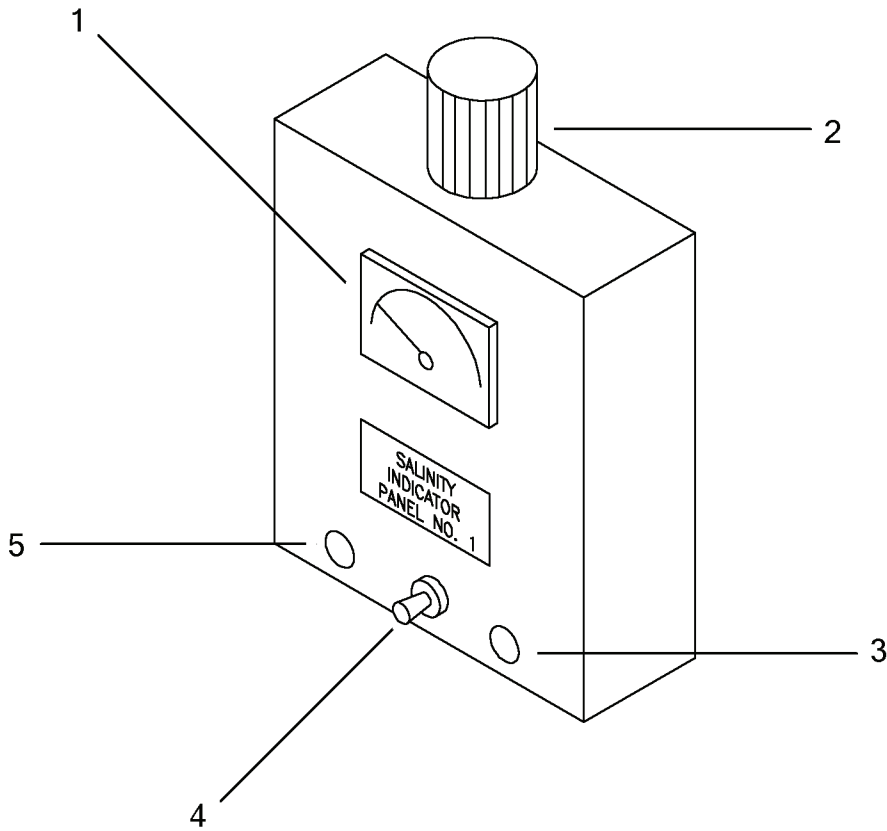

Figure 1-8. Salinity Control Panel.

Table 1-1. Salinity Control Panel.

No.	Control or Indicator	Function
1	Salinity Meter	Indicates level of salinity in product water.
2	Blue Strobe	Strobe Indicating product water not within specifications.
3	Red Lens	Indicates product water not within specifications.
4	Toggle Switch	Powers salinity control system.
5	Orange lens	Salinity power panel is operating.

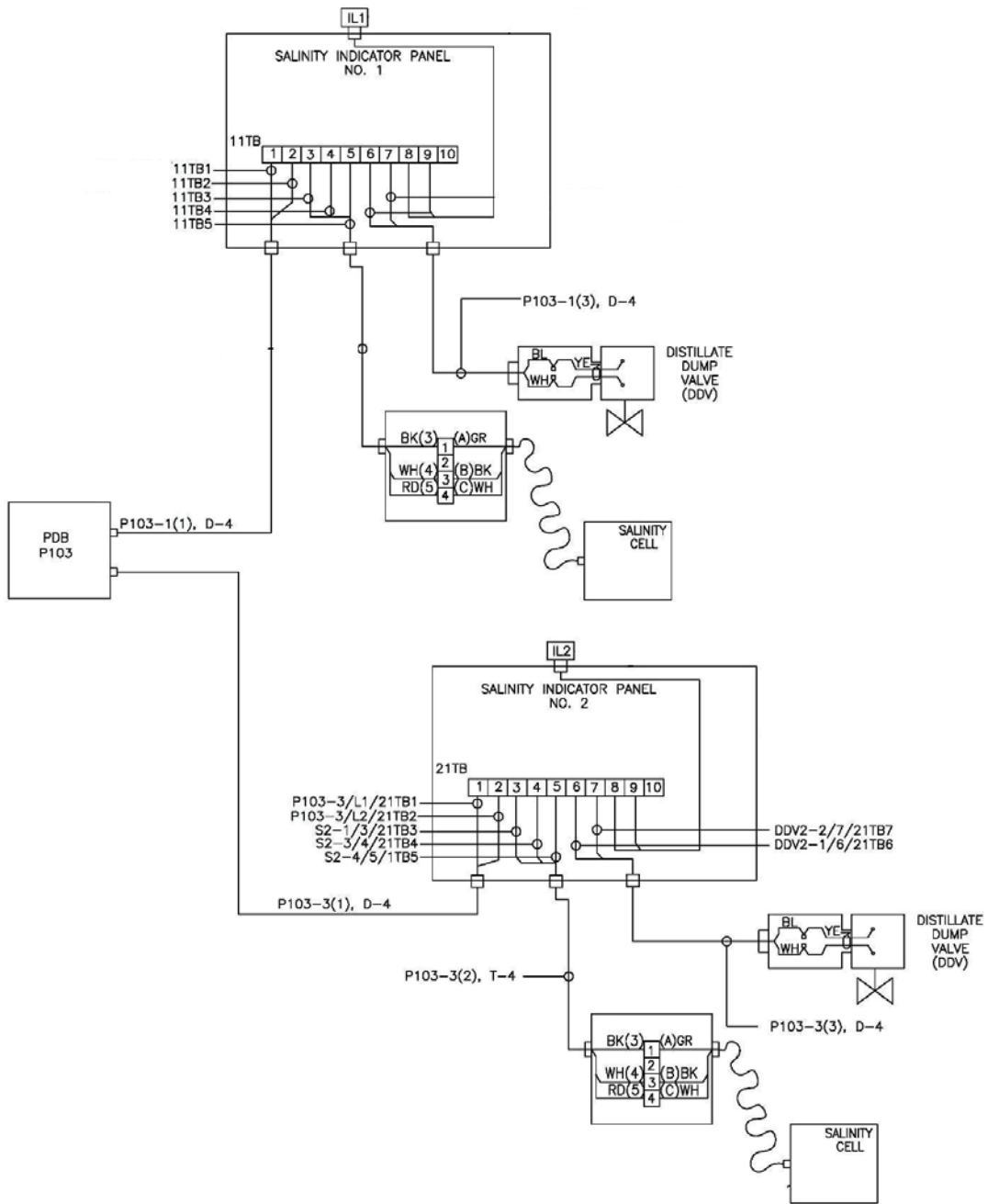

Fig 1-9. Salinity Control Electrical Diagram.

SECTION III. PRINCIPLES OF OPERATION

1-10. Principles Of Operation. One British Thermal Unit (BTU) is the standard for indicating the amount of heat required to raise the temperature of one pound of water 1°F. The BTU rejection rate of the engine waste heat is the key to successful seawater distillation. The BTUs/hr available to the Evaporator is a function of the relationship between jacket water temperature and jacket water flow rate, and varies with the horsepower developed by the engine. Thus, the developed horsepower will determine the amount of heat rejected by the engine (BTUs/hr), and will influence the quantity of freshwater produced. If the developed horsepower, or load, on the engine is increased, the engine water pump will increase its pumping rate, causing an increase in the engine BTU rejection rate, with a resultant increase in freshwater product output.

The output of the Evaporator will also be influenced by the temperature of the seawater. A decrease in seawater temperature will increase the product water output because the colder seawater flowing through the freshwater condenser will increase the rate of condensation of the rising vapor. Therefore, with 65°F seawater temperature, output will be approximately 20 percent greater than with 85°F seawater.

Table 1-2 is intended as a guide in computing the range of freshwater which can be produced under various operating conditions. For example, assume an HJ20C Waste Heat Evaporator installation with a 200 HP engine where the engine is developing 150 HP. On the chart, project a horizontal line over from 150 HP until it intersects with the JW Temp 140° diagonal line and JW Temp 185° diagonal line. (To give range, lowest to highest diagonals will be used.) Project these two points of intersection up to the top scale and read off the range. Thus, in the example, the product water output would be between 500 and 800 GPD.

Waste heat Evaporators do not require fuel since boiling heat is obtained from the hot jacket water. By utilizing this existing heat source, the Waste Heat Evaporator economically distills all the potable water required from the seawater (salt or brackish). The water produced is extremely pure, containing less than 4 ppm of total dissolved solids (0.25 grains of sea salt per gallon). Furthermore, this water always tastes fresh and clean, and, because it is soft, it is ideal for engine cooling, cooking, showering, and all other personal uses.

Waste Heat Evaporators operate on a simple distillation principle. Seawater is boiled at a low temperature (115°F to 140°F) under vacuum to create vapor. The vapor is then condensed into distillate. To operate this cycle, heat is utilized from the engine jacket water.

As illustrated in Figure 1-2, hot circulating jacket water is pumped through the seawater heater and is returned to the engine circulating system. This water supply is not affected in any way except that some heat is removed. Seawater is pumped continuously through the freshwater condenser. Most of the seawater is then discharged overboard. Some seawater, however, is directed from the freshwater condenser outlet through an Evaporator feed orifice into the Evaporator shell where it is boiled. The excess seawater, or brine, is continuously drawn off from the shell by the brine jet pump and discharged overboard.

The vapor produced by boiling the seawater passes up through a monel mesh separator where any droplets of water or entrained particles are removed. Thus, only pure vapor will enter the freshwater condenser section. This vapor passes over the tubes of the freshwater condenser where it is condensed by the cooler seawater flowing through the tubes. The resultant condensate is collected in the freshwater trough and is pumped from there to the storage tank by the freshwater pump. The Evaporator shell vacuum is maintained by evacuating the noncondensable gases from the shell with the vacuum jet pump.

A salinity sensing system keeps a careful check on the product water being produced. Should the product water contain 0.25 grains of sea salt per gallon or more, the salinity system will reject the water through a solenoid operated distillate dump valve (2, Figure 1-3), thereby protecting the freshwater tank from salty water.

This type of Evaporator is commonly fitted in parallel with the engine cooling system and does not interfere in any way with engine operation. Installation involves only five piping connections.

Waste Heat Evaporators are designed to produce potable water from seawater, when supplied with hot jacket water from the main engines as the energy source to evaporate seawater through valves. Potable water is produced by hot water from the propulsion engine while under power.

The source being used must inject sufficient heat to the jacket water to satisfy the Evaporator's heat requirements. The installation must not impair the efficiency of the engine or place the engine warranty in jeopardy.

Table 1-2. Freshwater Capacity Chart.

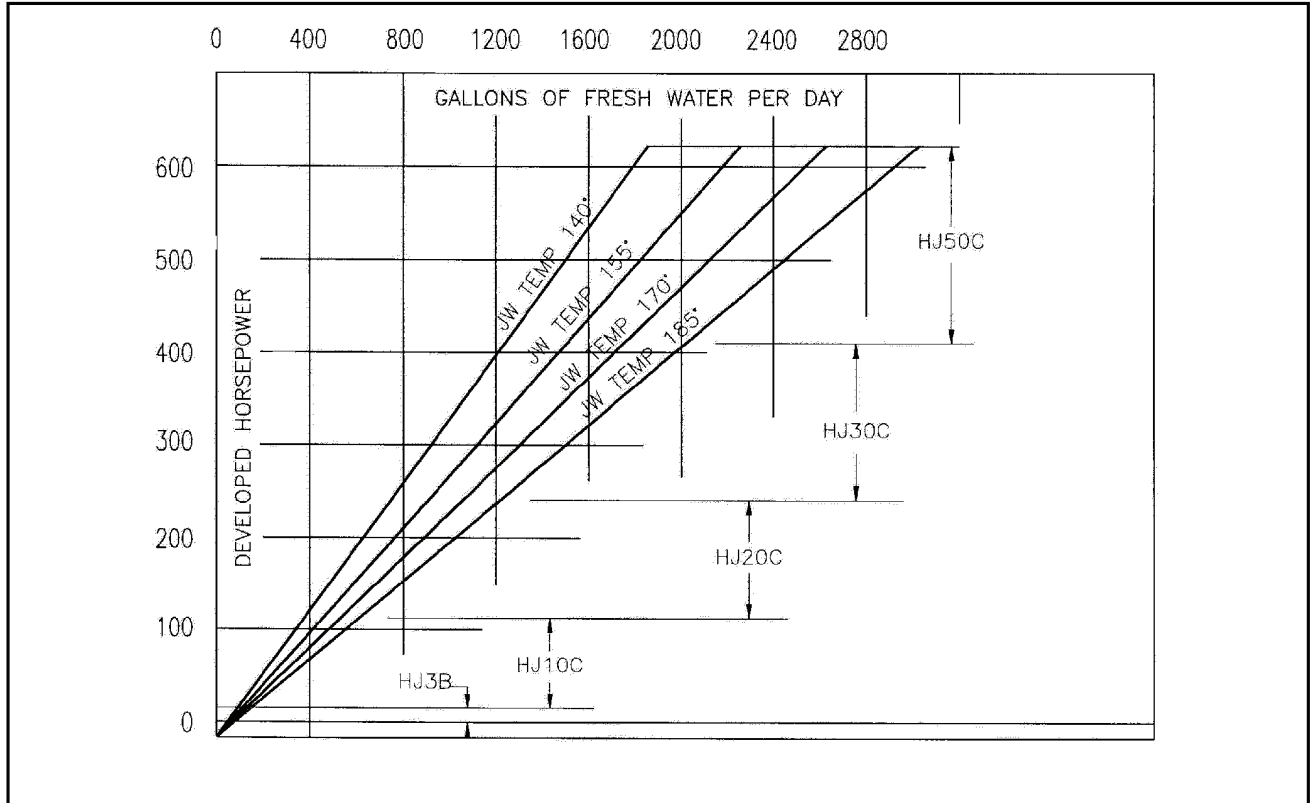

CHAPTER 2

UNIT MAINTENANCE INSTRUCTIONS

	<u>Page</u>
Section I Repair Parts, Special Tools; Test, Measurement, and Diagnostic Equipment (TMDE); and Support Equipment	2-1
Section II Service Upon Receipt	2-1
Section III Unit Preventive Maintenance Checks and Services (PMCS)	2-8
Section IV Unit Maintenance Troubleshooting	2-11
Section V Unit Maintenance Procedures.....	2-18
Section VI Preparation for Storage or Shipment	2-82

SECTION I. REPAIR PARTS, SPECIAL TOOLS; TEST, MEASUREMENT, AND DIAGNOSTIC EQUIPMENT (TMDE); AND SUPPORT EQUIPMENT

2-1. Common Tools and Equipment. For authorized common tools and equipment, refer to the Modified Table of Organization and Equipment (MTOE), CTA 50-970, Expendable/Durable Items (Except: Medical, Class V, Repair Parts, and Heraldic Items), CTA 50-909, Field and Garrison Furnishings and Equipment or CTA 8-100, Army Medical Department Expendable/Durable Items, as applicable to your unit.

2-2. Special Tools, TMDE, and Support Equipment. Special tools; test, measurement, and diagnostic equipment; and support equipment requirements are listed and illustrated in the Repair Parts and Special Tools List (RPSTL), TM 55-1905-223-24P-1. These items are also listed in the Maintenance Allocation Chart (MAC), Appendix B of this manual.

2-3. Repair Parts. Repair parts are listed and illustrated in the Repair Parts and Special Tools List (RPSTL), TM 55-1905-223-24P-1.

SECTION II. SERVICE UPON RECEIPT

2-4. Checking Unpacked Equipment.

- a. Inspect the equipment for damage incurred during shipment. If the equipment has been damaged, report the damage in accordance with the instructions of DA PAM 750-8.
- b. Check the equipment against the packing slip to see if the shipment is complete. Report all discrepancies in accordance with the instructions of DA PAM 750-8.
- c. Check to see whether the equipment has been modified.
- d. Remove and replace protective caps, plugs, inserts, wrappings, and tape when inspection/inventory is completed. Inspect piping openings for damage. Wipe off dirt, grease, or protective films at time of installation.
- e. Remove chocks from resilient mounted components.

2-5. Deprocessing Unpacked Equipment. After receipt and inspection of unpacked equipment, make sure that all packing materials, temporary braces, masking tape, etc., are removed from the material before installation.

2-6. Preliminary Servicing and Adjustment. To ensure that the Evaporator unit will be adequately inspected, serviced and operationally tested before it is subject to normal everyday use, the following procedures are required to be performed.

a. Evaporator Installation Checks.

WARNING

Always ensure affected circuits have been secured, locked out and tagged out. Performing maintenance with circuits energized may result in death or injury to personnel or equipment damage.

- (1) Mechanical installation Check. Check pumps, motors, gauges and connections to make certain that the components are securely mounted, bolts tightened.
- (2) Piping Installation Check. Before startup, check that the following fittings and connections are secured (Figures 1-1 through 1-4):
 - (a) Seawater inlet valve connections.
 - (b) Seawater strainer connections.
 - (c) Freshwater condenser bundle connections.
 - (d) Seawater heater bundle connection.
 - (e) Brine overboard discharge valve connections.
 - (f) Sea and freshwater piping, valves and flanges.
- (3) Electrical Installation Check. Before starting, check the following wiring:
 - (a) Ensure that all POWER switches (circuit breakers) are in the OFF position.
 - (b) Make visual check of control panel connection. If any wires are found not connected review drawing LCU2K-99-531-03, trace and reinstall.
 - (c) Check the main power line.
 - (d) Check the Salinity Indicator, Chemical Injection and UV Filter/Sterilizer connections.

b. Prestart Inspection.

- (1) Inspect piping system to include all fittings for serviceability.
- (2) Check chemical injection system for serviceability. Mix cleaning solution as described in Paragraph 2-4.
- (3) Inspect ultraviolet (UV) sterilizer (Figure 2-1) for serviceability.
- (4) Inspect salinity cell and power panel for connections, power, and serviceability.
- (5) Inspect jacket water pumps for leaks.
- (6) Inspect distillate freshwater pump (Figure 2-1) for leaks.

NOTE

Under normal conditions, operate one Evaporator at a time. Rotate between units on a weekly basis.

- c. Startup Procedures. (Figure 2-1).

WARNING

Do not operate Evaporator unit with ESW-9, ESW-7 and ESW-8 either throttled or closed as the internal tube bundles could rupture.

- (1) Align seawater piping valves:
 - (a) Ensure ASW system is operating.
 - (b) Open Brine Overboard, ESW-9.
 - (c) Open Seawater Outlet.
 - 1 For Evaporator No. 1 open ESW-7.
 - 2 For Evaporator No. 2 open ESW-8.

CAUTION

Open Seawater Supply valve slowly upon start up.

- (d) Open Seawater Supply.
 - 1 For Evaporator No. 1 open ESW-5.
 - 2 For Evaporator No. 2 open ESW-6.
- (e) Open Evap System Seawater Supply, SW-44.
- (2) Check seawater pressure gauge on Evaporator to make certain that at least 45 PSIG is indicated.

CAUTION

A minimum of 45 PSIG should be maintained on the gauge for satisfactory performance of the brine and vacuum jet pumps. Otherwise, neither pump will operate properly. DO NOT attempt to attain this pressure by throttling the seawater outlet valve. The overboard discharge line should be fully opened to keep back pressure at a minimum. Throttling of the stern tube cooling ASW valves may be necessary to establish proper pressure to the Evaporator. Stern tube cooling valves should be opened between one and two complete turns to allow proper stern tube cooling water flow.

WARNING

Chemical Hazard Warning: Cleaning treatment chemicals can cause severe burns. Avoid contact with skin. Use protective gloves and safety goggles when working on around or with any chemicals. Ensure adequate ventilation.

- (3) Align Chemical Feed system valves:
 - (a) Open Chemical Injection Tank Isolation valves.
 - 1 For Evaporator No. 1, open EIS-1.

- 2 For Evaporator No. 2, open EIS-2.
- (b) Open Evaporator Chemical Injection Isolation valves.
 - 1 For Evaporator No. 1, open EIS-3.
 - 2 For Evaporator No. 2, open EIS-4.
- (4) Energize chemical injection pump at circuit breaker in engine room power panel P103 and at local power switch.
- (5) Start Chemical Feed Pump. Adjust Feed rate to one-half gallon per hour. Pump setting is approximately 70-80%.
- (6) Close the Vacuum Release Valve. When vacuum reaches 25 HG, proceed to next step.
- (7) To start Evaporator No. 1, align jacket water valves to obtain hot engine coolant:
 - (a) Open DFW-100 and 103.
 - (b) Ensure Jacket Water Pump No.1 isolation valves DFW-501 and 502 are open.
- (8) To start Evaporator No. 2, align jacket water valves to obtain hot engine coolant:
 - (a) Open DFW-110 and 113.
 - (b) Ensure Jacket Water Pump No. 2 isolation valves DFW-601 and 602 are open.
- (9) To start Jacket Water pump:
 - (a) At MCC-P205, set jacket water pump 1 or 2 circuit breakers to "ON" position.
 - (b) Press jacket water pushbutton to "ON" position.
 - (c) After several minutes, boiling action can be observed in the sight glass on the Evaporator.
- (10) To start Distillate pump:
 - (a) Ensure freshwater line valve FW-909, and distillate discharge FW-908 are open.
 - (b) Open distillate pump discharge valves.
 - 1 For distillate pump No. 1, open FW-904.
 - 2 For distillate pump No. 2, open FW-905.
 - (c) At MCC-P205, set distillate pump 1 or 2 circuit breakers to "ON" position.

NOTE

Prior to starting the distillate pump, it is normal to observe a negative pressure at the distillate pump discharge indicator.

- (d) Use a flashlight behind the distillate discharge hose to observe water fill. When the water reaches the top of the plastic suction hose to the distillate pump, depress distillate pump start pushbutton. Open discharge valve FW-910 for Evapoartor No. 1 and FW-911 for Evaporator No. 2. Observe a normal discharge pressure of approximately 20 PSIG.

- (11) Activate Salinity Control System:
 - (a) At engine room power panel P103 set salinity panel 1 and 2 CB to "ON" position.
 - (b) Set salinity indicator panel power switch to "ON" and observe illumination of orange power lamp.
 - (c) During the 10 to 30 minute warm up time, the red alarm and flashing blue strobe lamps may be intermittently or constantly illuminated, indicating the dumping of poor quality water.
 - (d) If lamps continue to illuminate after 30 minutes, maintenance is required.
- (12) Turn on UV Sterilizer breaker at engine room power panel P103. Apply power to UV sterilizer 1 or 2 with local power switches.
- (13) Observe pressure/vacuum/flow rate readings to verify proper operation.

NOTE

In the event that freshwater produced by the waste heat Evaporator reaches or exceeds 4 parts per million of total dissolved solids (or 0.25 grains sea salt per gallon), the red alarm lamp will glow. At the same time, the distillate dump valve (2, Figure 1-3) will divert the product water to the overboard discharge line, preventing contamination of the freshwater tank (Figure 1-1).

The unit will normally warm up and make good water in 10 to 30 minutes. If, after 30 minutes, the unit is not making product water in the expected quantity, inspect the unit and check the troubleshooting guide for probable causes. The capacity chart (Table 1-2) provides approximate freshwater output.

2-7. SHUTDOWN PROCEDURE.

- a. Normal Shutdown (Figure 2-1).
 - (1) Turn off UV Sterilizers 1 and 2 at local power switches and circuit breakers at P103.
 - (2) Turn off Salinity Control systems at panel On/Off switch, at engine room power panel P103 and set Salinity Control system breakers to OFF.
 - (3) Stop Distillate pump by pressing Stop push button. Secure valves FW 909, and FW 908:
 - (a) To secure Evaporator No. 1, secure valves FW 904 and FW 910.
 - (b) To secure Evaporator No. 2, secure valves FW 905 and FW 911.

CAUTION

The vacuum release manual release globe valve located on the Evaporator must be opened upon shutdown in order to avoid flooding of the unit.

- (4) Open Evaporator Vacuum Release valve.

CAUTION

If Jacket Water Pump is allowed to circulate through the Evaporator after seawater is secured, excessive scaling of the Seawater Heater Tubes can occur.

- (5) Stop the Jacket Water pump by pressing the Stop pushbutton, at MCC-P205, set Jacket Water pump 1 or 2 circuit breakers to OFF.

- (6) At MCC-P205 set Distillate pumps 1 or 2 circuit breakers to OFF.
- (7) Realign Jacket Water valves:
 - (a) For Evaporator No. 1 close DFW-100 and 103.
 - (b) For Evaporator No. 2 close DFW-110 and 113.
- (8) Shut Seawater valves SW-44, and ESW-9:
 - (a) For Evaporator No1, shut ESW-5 and ESW-7.
 - (b) For Evaporator No. 2, shut ESW-6 and ESW-8.
- (9) Locally, turn off Chemical Injection System pumps and secure valves EIS-1, 2, 3 and 4. At engine room power panel P103, set Chemical Injection System breakers to OFF.

CAUTION

Always shut the intake (SW-44) and discharge (ESW-9) valves. When the Evaporator is located below the water line, it is particularly important that the intake and discharge valves be shut. Otherwise, with the vacuum broken, seawater will be siphoned in and the Evaporator will be flooded, thereby causing a saline condition in the freshwater trough. While not serious, this will cause an inconvenience when next starting up the plant to produce freshwater.

- b. Prolonged Shutdown. In the event of winter or a prolonged shutdown of several weeks or winter storage, the following procedures must be accomplished:
 - (1) Perform service procedures (Paragraph 2-11) to the Evaporator.
 - (2) Perform Shutdown procedures (Paragraph 2-7.a).
 - (3) Remove the drain plug from under the Evaporator, and allow the unit to drain.
 - (4) Disconnect discharge line and distillate hose from distillate pump, allowing the pump housing to drain. After pump is drained reinstall line and hose.
 - (5) Fill the Evaporator and lines with a freshwater hose at the drain plug. Repeating if necessary until the Evaporator and lines are thoroughly flushed.
 - (6) Completely drain freshwater from Evaporator and all lines.

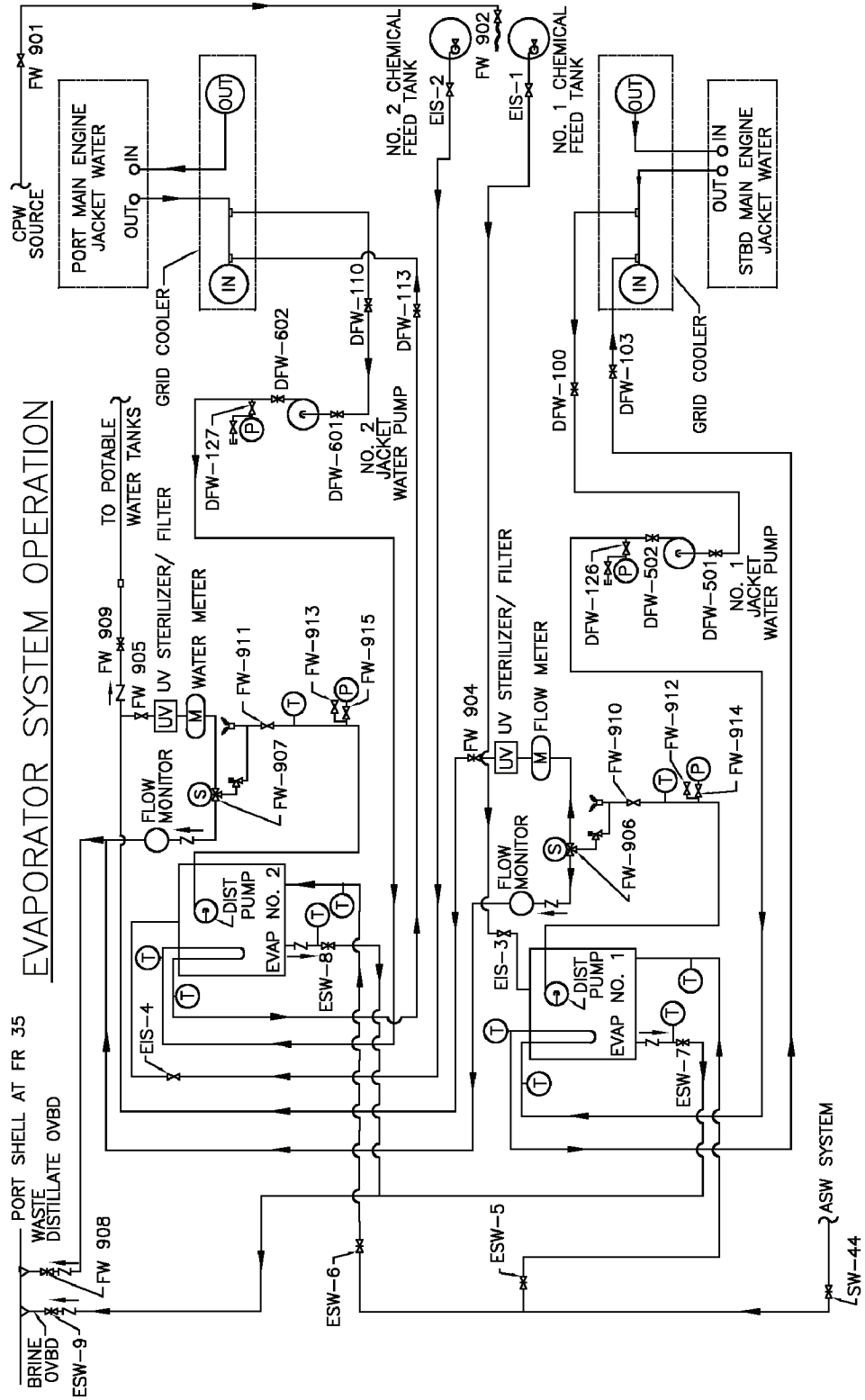

Figure 2-1. Waste Heat Evaporator Valve and Piping.

SECTION III. UNIT PREVENTIVE MAINTENANCE CHECKS AND SERVICES (PMCS)

2-8. Explanation of PMCS Table. Preventive Maintenance Checks and Services (PMCS) are designed to keep the equipment in good working condition by performing prescribed tests, inspections and services. The items to be serviced and the applicable PMCS procedures are listed in Table 2-1. The "Interval" column specifies when to perform a check or service. If required, PMCS may be accomplished more frequently than the indicated interval. The "Procedures" column describes how to perform the required checks and services. If the equipment does not operate as required, see Table 2-2, Troubleshooting. Report any malfunctions or failures on a DA Form 2404/5988E, Equipment Inspection and Maintenance Worksheet. In the "Item Number" column on DA Form 2404/5988E, record the appropriate item number from the PMCS Table (See Table 2-1).

Equipment Not Ready/Available. If the parameters listed in this column of Table 2-1 can not be resolved, it indicates that the system equipment is not ready and does not pertain to the vessels readiness.

Table 2-1. Preventive Maintenance Checks and Services

D - Daily W - Weekly M - Monthly Q - Quarterly S - Semiannually A - Annually AR - As Required

Item No.	Interval						Items To Be Inspected/Service	Procedures	Equipment Is Not Ready/ Available If:
	D	W	M	Q	S	A			
1							Salinity Cell	<p>NOTE</p> <p>Test reading should not be taken before the salinity cell has reached room temperature in not less than 20 minutes after removal from piping system.</p> <p>NOTE</p> <p>Cell electrodes should be bright. Corrosion, discoloration, and fouling of electrodes reduce the effectiveness of the salinity cell.</p> <p>Using salinity cell dummy load perform salinity resistance check (Paragraph 2-23). If salinity resistance check indicates a fault, clean the electrodes.</p> <p>NOTE</p> <p>The rate of product water flow out of the Evaporator must be observed to judge when to perform maintenance. A drop in flow rate is not always a sign of trouble. A slow decline in water production is normal during continued operation, even under ideal conditions.</p>	
2							Waste Heat Evaporator	<p>Check product water. Perform service every 150 hours.</p> <p>1. From the Evaporator log, select a flow rate representing normal flow, approximately 100 hours after last cleaning of the Evaporator. Note the temperature at which this flow was recorded.</p>	

Table 2-1. Preventive Maintenance Checks and Services

Item No.	Frequency							Items To Be Inspected/Service	Procedures	Equipment Is Not Ready/ Available If:
	D - Daily	W - Weekly Interval			M - Monthly	Q - Quarterly	S - Semiannually			
	D	W	M	Q	S	A	AR			
3			•				•	Salinity Power Panel	2. Divide this rate into the current flow rate (corrected to cancel out temperature differences). If the answer is 0.85 or less, clean the Evaporator. If the answer is 0.86 or greater, cleaning is not required. Access fuse and printed circuit board (Paragraph 2-22 and Figure 2-15). Visually inspect fuse and printed circuit board for broken, cracked, blemished, burnt and charred components or connections.	Salinity Power Panel inoperative or unable to maintain 0.25 GPG.
4						•		UV Sterilizer Lamp	CAUTION Be sure there are no marks or fingerprints on the UV lamp. Clean with denatured alcohol and cotton if necessary. Access UV Lamp by loosening the clamp and removing the chamber. Replace UV Lamp and Filter (Paragraph 2-15).	

SECTION IV. UNIT MAINTENANCE TROUBLESHOOTING

2-9. Troubleshooting. The common fault conditions that may be found during operation or maintenance of the equipment are listed in Table 2-2. Determine causes and accomplish corrective actions in the order listed. All symptoms that may occur, and all possible causes and corrective actions, are not listed herein. If a specific symptom is not listed, or if it continues after the corrective actions have been performed, notify a supervisor.

SYMPTOM INDEX		Troubleshooting Procedure Table 2-2
CHEMICAL FEED TREATMENT ASSEMBLY		
Chemical agitator not operating.		Item 24
Chemical injection pump motor fails to operate.		Item 23
Chemical injection pump will not prime.		Item 22
Chemical solution provided to Evaporator is not 1 GPH.		Item 17
Failure to pump or feed.		Item 19
Fitting leakage.		Item 21
Leakage around tubing connections.		Item 18
Unit loses prime.		Item 20
SALINITY CONTROL SYSTEM		
High salinity reading when water quality is determined to be good.		Item 6
Red alarm indicator and blue strobe on salinity panel illuminated.		Item 2
Salinity meter indicates salinity, but there is no alarm under any alarm setting.		Item 10
Salinity meter pointer becomes sluggish or sticks.		Item 8
Salinity meter reading does not vary, and there is voltage across its terminals.		Item 9
Salinity power panel alarm activates at incorrect set point.		Item 11
Salinity power panel does not operate properly.		Item 13
Salinity power panel does not work after the salinity cell has been disconnected for periodic examination and cleaning.		Item 14
Salinity power panel fuse is open with power across input terminals.		Item 12
Salinity power panel indicators do not illuminate.		Item 15
Salinity panel power switch fails to open or close the power circuit.		Item 16
When product water is good, the distillate dump valve remains open.		Item 7
WASTE HEAT EVAPORATOR MODEL HJ20C		
Evaporator is not producing water.		Item 4
Evaporator produces product water, but at a reduced capacity.		Item 3
Failure to maintain Main Engine Jacket Water level.		Item 5
Insufficient auxiliary seawater pump pressure (reading below 45 psig on seawater pressure gauge).		Item 1

Table 2-2. Troubleshooting

Malfunction	Test or Inspection	Corrective Action
-------------	--------------------	-------------------

NOTE

During all troubleshooting, it is assumed vessel power source is operating correctly, correct heat load available and all applicable valves are open.

1. Insufficient auxiliary seawater pump pressure (reading below 45 psig on seawater pressure gauge).
 - STEP 1. Clogged seawater strainer.
Remove strainer basket and clean (TM 55-1905-223-24-18-1, Paragraph 2-318).
 - STEP 2. Sea chest fouled.
Perform sea chest blow down procedures.
 - STEP 3. Malfunction of auxiliary seawater pump.
Inspect pump for leakage or breakage. Also inspect electrical connections (TM 55-1905-223-24-18-1, Paragraph 2-99).
2. Red alarm indicator and blue strobe on salinity panel illuminated.
 - STEP 1. Overboard discharge valve throttled or shut.
Fully open distillate discharge valve FW-908 (Figure 2-1).
 - STEP 2. Relay armature differential.
Turn salinity panel power off momentarily and then back on.
 - STEP 3. Salinity cell electrodes are dirty, have blemished surfaces or are fouled.
Service Salinity cell (Paragraph 2-23).
 - STEP 4. Insufficient auxiliary seawater pump pressure.
Remove seawater strainer basket and clean (TM 55-1905-223-24-18-1, Paragraph 2-318). Inspect pump for leakage or breakage (TM 55-1905-223-24-18-1, Paragraph 2-99).
 - STEP 5. Malfunctioning salinity panel.
Check electrical system for loose wires, relay, fuse or PCB. Tighten loose components or replace (Paragraph 2-22).
 - STEP 6. Clogged brine jet pump (high seawater level in shell).
Inspect seawater strainer basket for large holes.
Remove brine jet pump assembly. Remove, inspect and clean nozzle, replace if necessary (Paragraph 2-19).
 - STEP 7. Scaled Waste Heat Evaporator.
Service Waste Heat Evaporator (Paragraph 2-11).
 - STEP 8. Freshwater condenser leak.
Remove freshwater condenser bundle and inspect (Paragraph 2-19).
Perform hydrostatic test if necessary (Paragraph 3-11).
Replace if damaged (Paragraph 2-19).

Table 2-2. Troubleshooting - CONT

Malfunction	Test or Inspection	Corrective Action
-------------	--------------------	-------------------

NOTE

A reduction in capacity will be experienced when operating in warmer seawater (Paragraph 1-10).

3. Evaporator produces product water, but at a reduced capacity.

STEP 1. Insufficient shell vacuum.

Inspect sight glass and gasket, ensure intact (Paragraph 2-19).
Inspect all joints for tightness. Ensure vacuum release valve is closed.

Inspect seawater pressure gauge, throttle SW-44 (Figure 2-1) to maintain pressure.
(Should be a minimum of 45 psig.)

Remove vacuum jet pump. Remove, inspect and clean nozzle (Paragraph 2-19).
Inspect seawater strainer basket for holes (TM 55-1905-223-24-18-1, Paragraph 2-318).
Perform Hydrostatic test of seawater heater and freshwater condenser bundles (Paragraph 3-11).

STEP 2. Malfunctioning distillate pump.

Ensure freshwater valves are fully open. FW-904 for Evaporator No.1, FW-905 for Evaporator No.2.
Inspect distillate pump for leak. Repair as necessary (Paragraph 2-13).

STEP 3. Clogged feed orifice.

Remove feed orifice, clean and clear any obstructions (Paragraph 2-19).

STEP 4. Excessive scale on seawater heater bundle.

Service waste heat Evaporator (Paragraph 2-11).

4. Evaporator is not producing water.

STEP 1. Malfunctioning distillate pump. Perform repair procedures (Paragraph 2-13).

Inspect distillate pump for leaks or damage.
Inspect electrical connections, tighten as necessary.

STEP 2. Air leakage in suction line of distillate pump.

Inspect and reseal leaking connections.
Throttle discharge distillate valve (FW-908) (Figure 2-1) if necessary.

NOTE

If these causes do not appear at fault, refer to possible causes of malfunctions 1 STEP 1, 1 STEP 2, 2 STEP 1, 2 STEP 6, 3 STEP 1 and 3 STEP 2.

5. Failure to maintain Main Engine Jacket Water level.

STEP 1. Seawater heater bundle leaking.

Verify jacket water level through main engine expansion tank sight glass and evidence of jacket water (engine coolant) in Evaporator through the Evaporator sight glass (PMCS, TM 55-1905-223-10).

Remove Seawater Heater bundle assembly and inspect (Paragraph 2-17).
Perform Hydrostatic test of bundle. Replace if necessary (Paragraph 3-11).

Table 2-2. Troubleshooting - CONT

Malfunction	Test or Inspection	Corrective Action
6. High salinity reading when water quality is determined to be good.	STEP 1. Salinity cell.	Service and test cell electrodes and insulator. If problem still exists, replace the cell (Paragraph 2-23).
7. When product water is good the distillate dump valve remains open.	STEP 1. Pull power dump relay from PCB (A click should be heard), if there is no click replace the power dump relay (3, Figure 2-15 and Paragraph 2-22). If a click is heard replace or repair the distillate dump valve (Paragraph 2-14). STEP 2. Faulty power dump relay.	Replace power dump relay (Paragraph 2-22).
8. Salinity meter pointer becomes sluggish or sticks.	STEP 1. Faulty meter.	Replace meter (Paragraph 2-22).
9. Salinity meter reading does not vary, and there is voltage across its terminals.	STEP 1. Faulty meter.	Replace meter (Paragraph 2-22).
10. Salinity meter indicates salinity, but there is no alarm under any alarm setting.	STEP 1. Faulty printed circuit board.	Replace printed circuit board (Paragraph 2-22).
11. Salinity power panel alarm activates at incorrect set point.	STEP 1. Misadjusted alarm set point. STEP 2. Faulty printed circuit board.	Reset alarm set point (Paragraph 2-22). Replace printed circuit board (Paragraph 2-22).
12. Salinity power panel fuse is open with power across input terminals.	STEP 1. Blown fuse.	Replace fuse and visually inspect fuse and PCB for broken, cracked, blemished, burnt and charred components or connections (Paragraph 2-22).

NOTE

After it has been established that the meter, relay, cell, and cell wiring are good and the salinity power panel does not operate properly, printed circuit board may be at fault.

13. Salinity power panel does not operate properly.
- STEP 1. Malfunctioning printed circuit board.
Replace printed circuit board (Paragraph 2-22).

Table 2-2. Troubleshooting - CONT

Malfunction	Test or Inspection	Corrective Action
14. Salinity power panel does not work after the salinity cell has been disconnected for periodic examination and cleaning.	STEP 1. Incorrect cell replacement.	Rewire cell to plug and/or panel properly, noting the color coding (Paragraph 2-23).
15. Salinity Power panel indicators do not illuminate.	STEP 1. Faulty light bulb.	Replace bulb (Paragraph 2-22).
16. Salinity power panel switch fails to open or close the power circuit.	STEP 1. Faulty switch.	Replace the switch (Paragraph 2-22).
17. Chemical solution provided to Evaporator is not 1 GPH.	STEP 1. Chemical injection feeder setting too low or high.	Adjust chemical injection feeder setting. (Feeder must be operating during the adjustment) (Paragraph 2-25.)
	STEP 2. Scale at injection point.	Service injection point (Paragraph 2-25).
	STEP 3. Solution container allowed to run dry.	Refill the tank with Ameroyal and freshwater mixture (Paragraph 2-24).
18. Leakage around tubing connections.	STEP 1. Worn tube ends.	Repair or replace tubing (Paragraph 2-25).
19. Failure to pump or feed.	STEP 1. Leak in suction side of pump.	Inspect tubing for cracks or damage, repair or replace (Paragraph 2-25). Check for loose fittings, tighten as necessary.
	STEP 2. Valve seats not sealing.	Clean valve seats, or replace (Paragraph 2-25).
	STEP 3. Low solution level.	Solution must be above foot valve (Paragraph 2-24).
	STEP 4. Diaphragm ruptured.	Replace diaphragm (Paragraph 2-25).

Table 2-2. Troubleshooting - CONT

Malfunction
Test or Inspection**Corrective Action**

19. Failure to pump or feed (cont).

STEP 5. Pump head cracked or broken.

Replace pump head (Paragraph 2-25).

Ensure fittings are hand tight only. Using pliers or wrench on fittings can crack pump head.

STEP 6. Pump head contains air.

Close all pressure valves, and loosen outlet tubing connection at discharge point. Remove head assembly, inspect ball and seat valves. Apply a few drops of solution to the ball check and seat valves.

Set feeder dial to maximum rate and turn on feeder. When pump is primed, reconnect all tubing connections (Paragraph 2-25).

20. Unit loses prime.

STEP 1. Dirty back check valve.

Service or replace back check valve (Paragraph 2-25).

STEP 2. Ball checks not seating or not sealing properly.

Inspect and service back check, head or foot valve assemblies or replace (Paragraph 2-25).

STEP 3. Solution container has run dry.

Refill container with proper chemical (Paragraph 2-24).

21. Fitting leakage.

STEP 1. Loose fittings.

Ensure all fittings are hand tight.

STEP 2. Broken or worn gasket.

Inspect gaskets, and replace if broken or worn (Paragraph 2-25).

22. Chemical injection pump will not prime.

STEP 1. Too much pressure at discharge.

Close all pressure valves, and loosen outlet tubing connection at discharge point. Remove head assembly, inspect ball and seat valves. Apply a few drops of solution to the ball check and seat valves.

Set feeder dial to maximum rate and turn on feeder. When pump is primed, reconnect all tubing connections (Paragraph 2-25).

STEP 2. Valves are not sealing.

Remove all valves, inspect for damaged or worn components, service and replace damaged components (Paragraph 2-25).

STEP 3. Feeder dial not set at maximum.

Always prime pump with output dial set at maximum rated capacity (Paragraph 2-25).

Table 2-2. Troubleshooting - CONT

Malfunction	Test or Inspection	Corrective Action
<hr/>		
23. Chemical injection pump motor fails to operate.		
	STEP 1. No power to chemical injection pump.	Ensure power source is provided to motor, check local switch and circuit breaker.
	STEP 2. Remove and replace motor (Paragraph 2-25).	
24. Chemical agitator not operating.		
	STEP 1. Check local power switch and circuit breakers.	
	STEP 2. Remove and replace motor (Paragraph 2-26).	

SECTION V. UNIT MAINTENANCE PROCEDURES

MAINTENANCE OF WASTE HEAT EVAPORATOR

2-10. The unit level Replacement and Repair tasks of the waste heat Evaporator are accomplished through maintenance procedures in Paragraphs 2-11 through 2-26 of this chapter.

2-11. Waste Heat Evaporator Model HJ20C. (Figures 2-2 through 2-4)

This task covers: a. Inspect, b. Test, c. Service.

INITIAL SETUP

Tools

Tool Kit, General Mechanic's,
5180-00-699-5273

Equipment Condition

TM 55-1905-223-10, Waste Heat Evaporator shutdown and tagged "Out of Service – Do Not Operate" (FM 55-502).

Materials/Parts

Citric Acid, Item 4, Section II, Appendix C
Gloves, Chemical, Item 6, Section II, Appendix C
Goggles, Item 7, Section II, Appendix C
Pail, 5 Gallon, Item 11, Section II, Appendix C
Respirator, Particulate, Item 13, Section II, Appendix C
Warning, Tag Item 18, Section II, Appendix C
Wiping, Rags Item 19, Section II, Appendix C

INSPECT

Inspection of the Waste Heat Evaporator is accomplished through Preventive Maintenance Checks and Services (PMCS), Table 2-1.

WARNING

Always ensure affected circuits have been secured, locked out and tagged out. Performing maintenance with circuits energized may result in death or injury to personnel or equipment damage.

TEST

- a. Evaporator Hydrostatic Testing. A simple hydrostatic test will locate any suspected leak in the gaskets, piping connections, sight glass or Evaporator shell joints.
 - (1) With the Evaporator closed off (Paragraph 2-7), disconnect the plastic freshwater hose (3, Figure 2-3) at the Evaporator shell and plug the pipe elbow.
 - (2) Open the auxiliary seawater piping SW-44 (Figure 2-2) and the seawater feed valve:
 - (a) For Evaporator No. 1 ESW-5.
 - (b) For Evaporator No. 2 ESW-6.

CAUTION

DO NOT EXCEED 12 PSIG. The safety relief valve installed on the Evaporator is set for 20 pounds to prevent damage from possible over pressurization.

- (3) Start the seawater pump (Paragraph 2-6.c) until the Evaporator fills, and the compound gauge (4, Figure 2-4) reads between 10 and 12 psig.
- (4) Secure the pump and observe gaskets, piping, sight glass and shell joints for leaks or damage.

SERVICE

WARNING

Chemical Hazard Warning: Liquid may be contaminated. Avoid contact with skin and eyes. Use protective gloves and safety goggles when working on or around the Distillate Pump Assembly.

CAUTION

Ensure compliance with Federal and International laws prior to disposal of Hazardous Materials.

NOTE

Keeping the seawater heater tubes free of scale is important. Any buildup of scale on the tubes will act as insulation and slow down the boiling action. Acid cleaning requirements vary with the installation. For example, continuous running of the plants will necessitate more frequent cleaning than intermittent running. Operation at maximum rated capacity will necessitate more frequent acid cleaning than operation at less than maximum capacity. Operation in cold seawater will necessitate less frequent acid cleaning than operation in warm (85°F) seawater. Operation on hot (185°F or higher) jacket water will necessitate more frequent acid cleaning than with cooler (160°F) jacket water. Typical times of operation between acid cleaning to maintain peak efficiency and capacity will vary depending on operating conditions. If desired, a chemical feed system using AMEROYAL can be used and acid cleaning frequency will be extended to 500 hours or more. It is recommended that a chemical feed system and AMEROYAL be utilized for all the HJ series operating on steam (Paragraph 2-24).

NOTE

This service procedure only covers acid cleaning. Chemical pretreatment is covered under Chemical Feed Treatment Assembly System (Paragraph 2-24).

a. Acid Cleaning the Evaporator of Heavy Scale with ANHYDROUS CITRIC ACID.

- (1) Obtain a 5-gallon container to hold the chemical cleaning solution.
- (2) Mix the following quantities of cleaning solution in the container:

Model No.	Freshwater	CITRIC ACID
HJ20C	2.0 gal.	1.00 lb

NOTE

Mix thoroughly to dissolve the chemical in the water. To dissolve quickly, the chemical cleaning solution should be mixed with freshwater whenever possible. In case of emergency, the chemical can be mixed with seawater.

- (3) Install a hose (approximately 3 feet long) from the vacuum release valve (11, Figure 2-4) connection to the 5-gallon container.

NOTE

The Evaporator is to be in the operational mode.

- (4) Deenergize the distillate salinity panel which deenergizes the distillate dump valve. Keep the Evaporator in the operating mode.
- (5) Open the vacuum release valve and draw the chemical solution into the Evaporator shell.
- (6) Immediately close the vacuum release valve when all solution in the container is drawn into the Evaporator.
- (7) Wait approximately 15 minutes after adding the acid, and then turn on the salinity panel.
- (8) When the salinity indicating needle indicates 0.25 grains per gallon (GPG) or below, the distillate can be directed to the potable storage tank. The Evaporator will be in the normal operating mode.

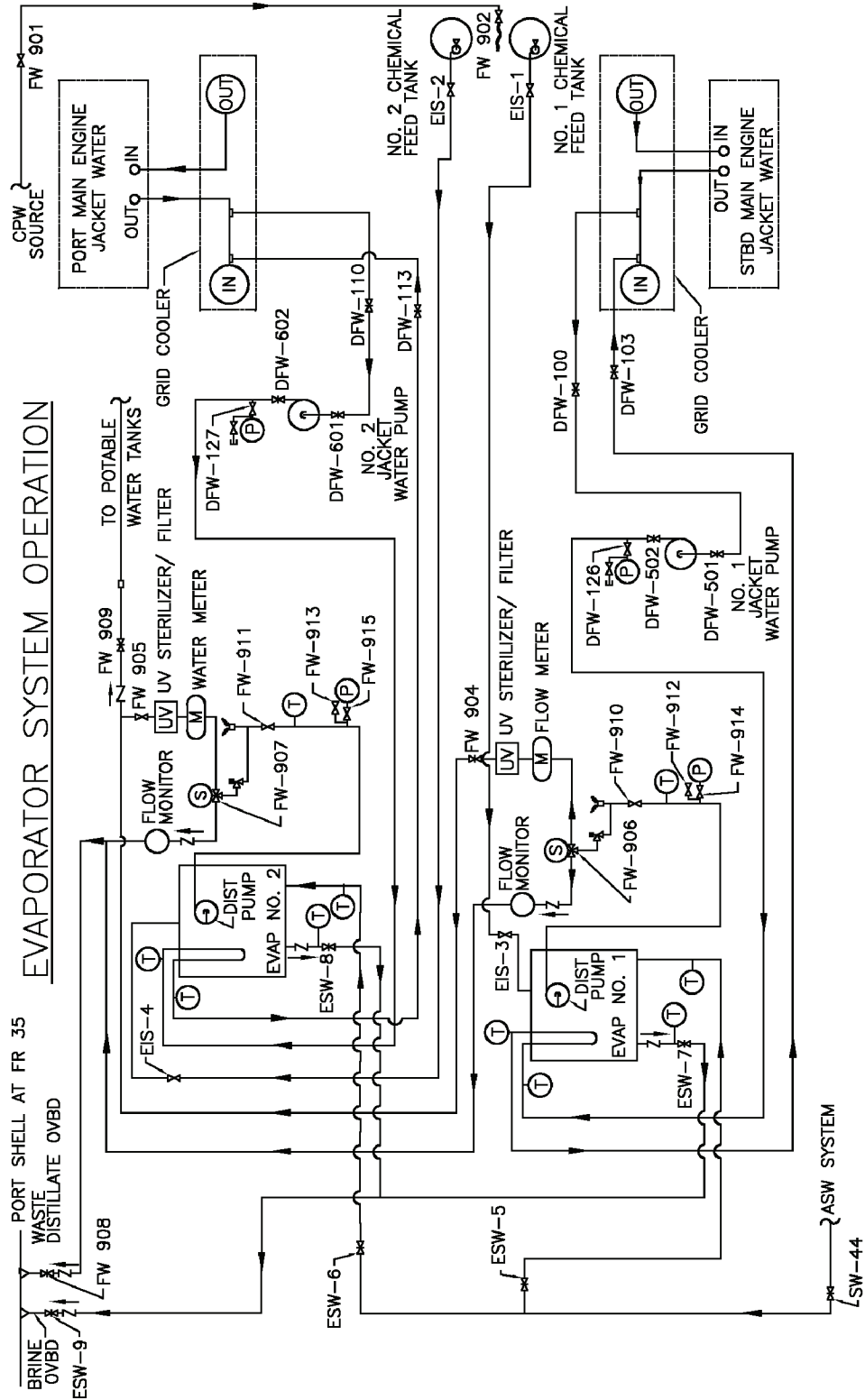

Figure 2-2. Waste Heat Evaporator.

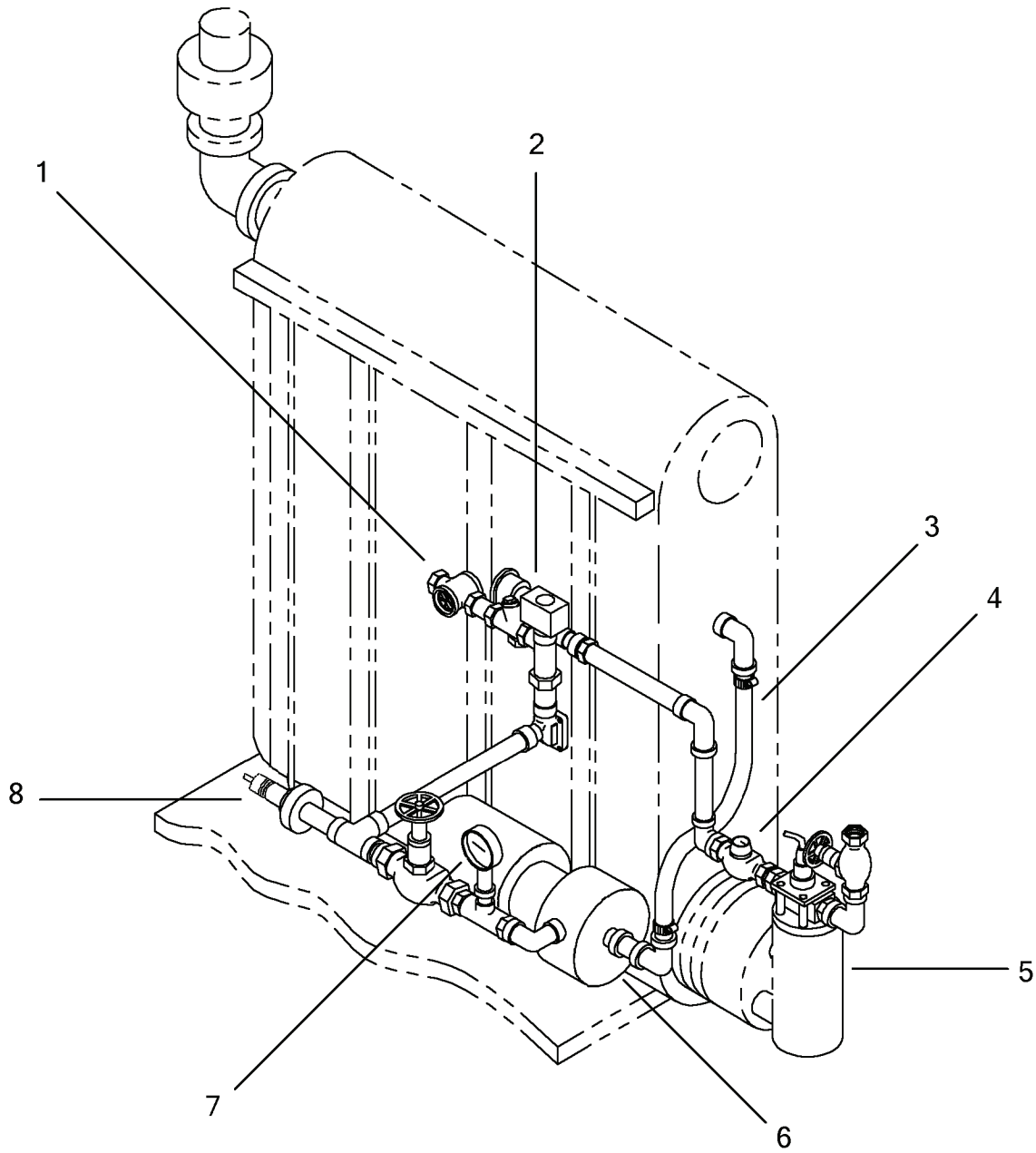

Figure 2-3. Waste Heat Evaporator Distillate Piping Group.

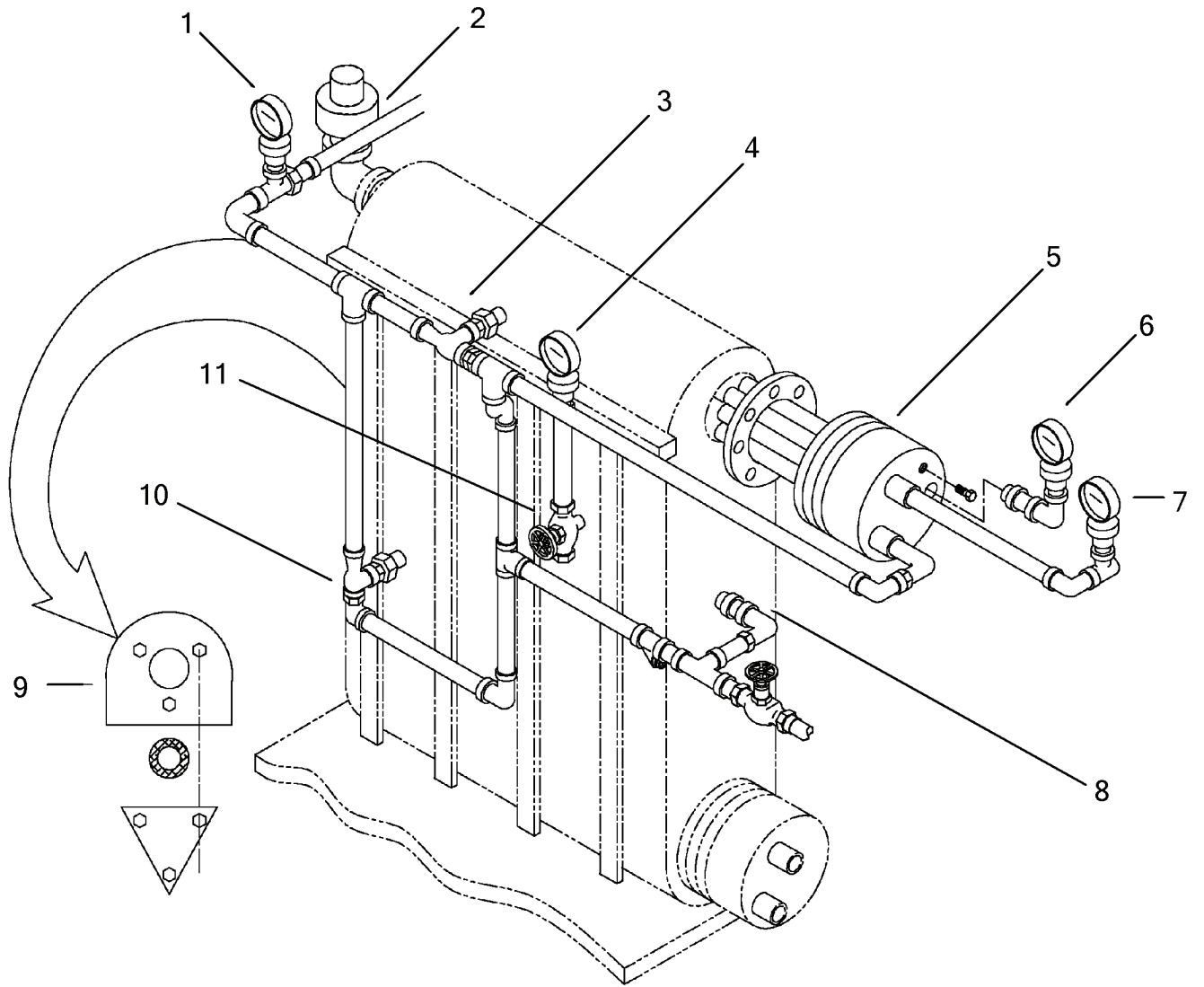

Figure 2-4. Waste Heat Evaporator Feed Water Piping Group.

2-12. Distillate Piping Group. (Figures 1-9, 2-5 and 2-9)

This task covers: a. Repair.

INITIAL SETUP

Tools

Tool Kit, General Mechanic's,
5180-00-699-5272
Tool Kit, Welder's,
5180-00-754-0661
Torch Outfit, Cutting and Welding Medium Duty,
Oxygen and Acetylene, 3433-00-357-8116
Tool Kit, Electrician's
5180-00391-1087

Equipment Condition

TM 55-1905-223-10, Waste Heat Evaporator
shutdown and tagged "Out of Service – Do Not
Operate" (FM 55-502).

Materials/Parts

Pail, Utility, Item 12, Section II, Appendix C
Teflon Tape, Item 16, Section II, Appendix C
Warning Tags, Item 18, Section II, Appendix C
Wiping Rags, Item 19, Section II, Appendix C

WARNING

Always ensure affected circuits have been secured, locked out and tagged out. Performing maintenance with circuits energized may result in death or injury to personnel or equipment damage.

NOTE

Some piping and piping connections are welded assemblies and a cutting and welding torch kit is required. All parts must be manufactured from the same material. Refer to TB-55-1900-204-24 (Welding on Watercraft).

REMOVAL

- a. To remove the distillate piping group (Figure 2-5), proceed as follows:
 - (1) At power panel P103 turn off circuit breaker for salinity control system.
 - (2) In the salinity control panel identify and label distillate dump valve wires and remove.
 - (a) For Evaporator No. 1, 11TB 6 and 7 (Figure 1-9).
 - (b) For Evaporator No. 2, 21TB 6 and 7 (Figure 1-9).
 - (3) In the salinity control panel identify and label salinity cell wires and remove.
 - (a) For Evaporator No. 1, 11TB 3, 4 and 5 (Figure 1-9).
 - (b) For Evaporator No. 2, 21TB 3, 4, and 5 (Figure 1-9).

- (4) Open vacuum release valve (11, Figure 2-4), to release the internal vacuum.
 - (5) Place pail under distillate pump inlet (8, Figure 2-5) to catch distillate water.
 - (6) Remove lower hose clamp (5), and drain hose and Evaporator reservoir.
 - (7) Remove upper hose clamp (5) and flexible hose (6).
 - (8) Place container under tee connector (12) to catch remaining distillate water.
 - (9) Remove salinity cell (13) and allow draining of piping system.
 - (10) Disconnect piping from the distillate dump sight glass (1).
 - (11) Loosen the union fittings (3, 9 and 11) and remove the piping group.
- b. To remove the distillate thermometer (10), unscrew from tee connector.
 - c. After the piping group is removed, the distillate dump sight glass (1), distillate dump valve (2), product water meter (4), Ultraviolet (UV) sterilizer (7), pressure regulating valve (14) and check valve (15) can be removed by disconnecting the appropriate piping.

NOTE

Apply Teflon Tape to all threaded fittings.

NOTE

Some piping and piping connections are welded assemblies and a cutting and welding torch kit is required. All parts must be manufactured from the same material. Refer to TB-55-1900-204-24 (Welding on Watercraft).

REPAIR

- a. Repair is by replacement of the pressure regulating valve (14), check valve (15), distillate dump site glass (1) and damaged or worn associated piping (Figure 2-5).
- b. To repair the Distillate Dump valve, refer to Paragraph 2-14.
- c. To repair the UV Sterilizer, refer to Paragraph 2-15.
- d. To repair the Product Water Flow Meter, refer to Paragraph 2-16.
- e. To repair the Salinity Cell, refer to Paragraph 2-23.
- f. To repair associated pipe fittings:
 - (1) Remove applicable associated pipe fittings as describe in removal procedure (a) and TB-55-1900-204-24 (Welding on Watercraft).
 - (2) Install new or repaired pipe or pipe fitting as described in replacement procedure b.
- g. To repair the flexible hose (6):

- (1) Remove hose as described in removal procedure a.
- (2) If the hose ends are cracked or split, cut the damaged section off with a knife.
 - (a) If the hose damage is unable to be corrected by cutting then replacement is necessary.
- (3) Install repaired or new hose as described in replacement procedure b.

NOTE

Apply Teflon Tape to all threaded fittings.

NOTE

Some piping and piping connections are welded assemblies and a cutting and welding torch kit is required. All parts must be manufactured from the same material. Refer to TB-55-1900-204-24 (Welding on Watercraft).

REPLACEMENT

- a. Replace the distillate dump sight glass (1), distillate dump valve (2), product water meter (4), Ultraviolet (UV) Sterilizer (7), check valve (15) and pressure regulating valve (14), by connecting to the appropriate piping.
- b. To replace the distillate piping group (Figure 2-5), proceed as follows:
 - (1) Install the piping group in position; tighten the union fittings (3, 9 and 11).
 - (2) Reconnect the piping to the distillate dump sight glass (1).
 - (3) Reconnect the salinity cell (13) to the piping system.
 - (4) Replace flexible hose (6) with hose clamps (5).
 - (5) In the salinity control panel reconnect distillate dump valve wires.
 - (a) For Evaporator No. 1, 11TB 6 and 7 (Figure 1-9).
 - (b) For Evaporator No. 2, 21TB 6 and 7 (Figure 1-9).
 - (6) In the salinity control panel reconnect salinity cell wires.
 - (a) For Evaporator No. 1, 11TB 3, 4 and 5 (Figure 1-9).
 - (b) For Evaporator No. 2, 21TB 3, 4, and 5 (Figure 1-9).
- c. Replace the distillate thermometer (10, Figure 2-5), screw into tee connector.
- d. Restore electrical power, start the Evaporator, and conduct operational check (Paragraph 2-6.c).
- e. Operate the WHE (Paragraph 2-6.c) and check covers, gaskets, piping and hoses for leaks, correct as necessary.

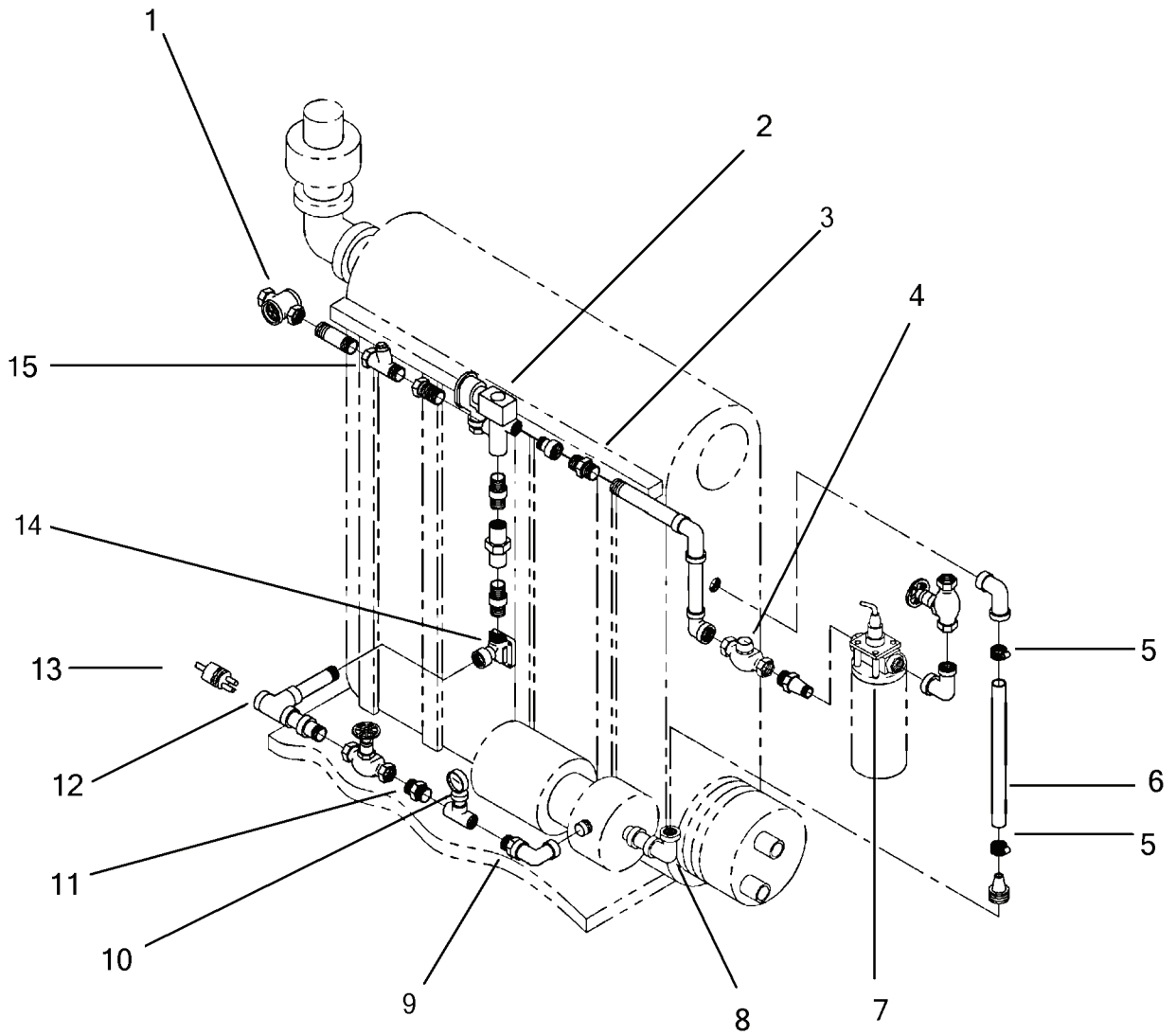

Figure 2-5. Distillate Piping Group.

2-13. Distillate Pump Assembly. (Figures 2-5 and 2-6)

This task covers: a. Inspect, b. Repair, c. Replacement.

INITIAL SETUP

Tools

Tool Kit, General Mechanic's,
5180-00-699-5273
Strap Wrench, Item 15, Section II, Appendix C
Torque Wrench, Item 17, Section II, Appendix C

Equipment Condition

TM 55-1905-223-10, Waste Heat Evaporator
shutdown and tagged "Out of Service - Do Not
Operate" (FM 55-502).

Materials/Parts

Mechanical Seal Parts Kit, P/N 93466-63 Non-Asbestos
Impeller, P/N 93466-34
Antiseize Compound, Item 3, Section II, Appendix C
Motor Oil, Item 9, Section II, Appendix C
Pail, 5-gallon, Item 11, Section II, Appendix C
Teflon Tape, Item 16, Section II, Appendix C
Warning Tag, Item 18, Section II, Appendix C
Wiping Rags, Item 19, Section II, Appendix C

INSPECT

Inspection of the Distillate Pump Assembly is accomplished through Preventive Maintenance Checks and Services (PMCS, TM 55-1905-223-10).

WARNING

Always ensure affected circuits have been secured, locked out and tagged out. Performing maintenance with circuits energized may result in death or injury to personnel or equipment damage.

WARNING

Chemical Hazard Warning: Liquid may be contaminated. Avoid contact with skin and eyes. Use protective gloves and safety goggles when working on or around the Distillate Pump Assembly system.

CAUTION

Ensure compliance with Federal and International laws prior to disposal of Hazardous Materials.

REMOVAL

To remove the distillate pump assembly (Figure 2-6), proceed as follows:

- a. Remove conduit box cover (8).
- b. Identify, label and disconnect wires in conduit box to ensure proper motor rotation after installation.
 - (1) Proper motor rotation is counterclockwise facing shaft end.

CAUTION

Ensure compliance with Federal and international laws prior to overboard discharge of hazardous materials.

If the liquid is contaminated, it should be treated as HAZMAT and disposed of properly.

- c. Utilizing a suitable container, disconnect hose connections from pump.
 - (1) Disconnect lower hose clamp (5, Figure 2-5) from flexible hose at the inlet.
 - (2) Remove coupling (9) from piping at the outlet.
 - (3) Dispose of liquid in accordance with current regulations.
- d. Remove capscrews (3, Figure 2-6) from suction cover (4). Note the condition of gasket (5), which adheres either to the suction cover (4) or the casing (1).
- e. Remove impeller (6) by turning in a counterclockwise direction.
 - (1) Use the strap wrench to turn impeller (6) in a counterclockwise direction to remove from the shaft.
 - (2) A screwdriver slot on the motor shaft opposite pump is provided for steadying the shaft.
 - (3) File or polish out any wrench marks before reinstalling.
- f. The pump is now sufficiently dismantled for completing most repairs and replacements, including the mechanical seal.
- g. Remove rotating parts of the mechanical seal (2) and O-ring (7) from the shaft-like extension of the impeller.
 - (1) If the flexible diaphragm or bellows stick tightly, it may be loosened by soaking in oil or cut away with a knife.
- h. Remove casing (1) by turning counterclockwise and disconnect from motor (9).
- i. Remove foundation bolts and nuts to remove the motor.

CAUTION

Care should be observed that cleansing material and oil are free of foreign particles.

Do not use grease or allow grease on the sealing surfaces.

NOTE

Apply Teflon Tape to all threaded fittings.

REPAIR

- a. Repair of the distillate pump assembly is by replacement of the mechanical seal, impeller, gaskets and O-rings.
- b. An antisieze lubricant was originally applied to the inside diameter of the impeller which is threaded onto the shaft. Add fresh lubricant to the inside diameter, not to the shaft, and replace the O-ring.
- c. One drop of oil applied to the shaft extension will prevent the O-ring from binding on the shaft while assembling impeller.
- d. The complete mechanical seal will be replaced whenever there is any leakage at the shaft or whenever the pump is dismantled to the point of removing the shaft, mechanical seal and O-rings.
- e. Repair of the pump motor is by replacement only.

REPLACEMENT

To replace the distillate pump assembly (Figure 2-6), proceed as follows:

- a. Place motor on foundation.
- b. Align motor feet bolt holes over bolt holes in foundation and insert mounting bolts with nuts.
- c. Install pump casing (1) to motor by inserting studs into motor and rotating in a clockwise direction.

CAUTION

Care should be observed that cleansing material and oil are free of foreign particles.

Do not use grease or allow grease on the sealing surfaces.

Do not continue to slide the assembly down the shaft once the rotating assembly has engaged the spring. Inspect the carbon sealing face, and remove any foreign particles with a lint-free cloth or tissue. Avoid skin contact on mating surfaces of mechanical seal (2).

- d. Replace the mechanical seal (2) with O-ring (7) on the shaft-like extension of the impeller (6).
(1) Lightly oil (SAE-10) the mechanical seal to facilitate installation of the bellows or diaphragm.
- e. Thoroughly clean gasket sealing surfaces with a clean cloth.

- f. Install the impeller (6) with mechanical seal (2) on the shaft.
 - (1) Lightly lubricate inside diameter of impeller with antiseize. Do not lubricate the shaft.
 - (2) Turn the impeller clockwise onto the threaded shaft, utilizing the slot on opposite end to steady the shaft. Hand tighten impeller, or use strap wrench.
- g. Inspect the casing and gasket surfaces for cleanliness. Remove all foreign matter so that gaskets will have a proper seal.
- h. Install the suction cover (4) and gasket (5), secure with capscrews (3).
- i. Reconnect hose connections to pump:
 - (1) Connect coupling at outlet (9, Figure 2-5) side of pump.
 - (2) Connect flexible hose (6) to coupling (8), securing with hose clamp (5).

WARNING

Always ensure affected circuits have been secured, locked out and tagged out. Performing maintenance with circuits energized may result in death or injury to personnel or equipment damage.

- j. Connect wires in conduit box as tagged on removal to ensure proper motor rotation.
 - (1) Proper motor rotation is counterclockwise facing shaft end.
 - (2) If motor rotation is not counterclockwise reverse any two incoming power leads.
- k. Install conduit box cover (8, Figure 2-6).
- l. Replace and inspect piping system for leaks, and test pump/motor for operation.
- m. Restore electrical power, start the Evaporator, and conduct operational check (Paragraph 2-6.c).
- n. Operate the WHE (Paragraph 2-6.c) and check covers, gaskets, piping and hoses for leaks, correct as necessary.

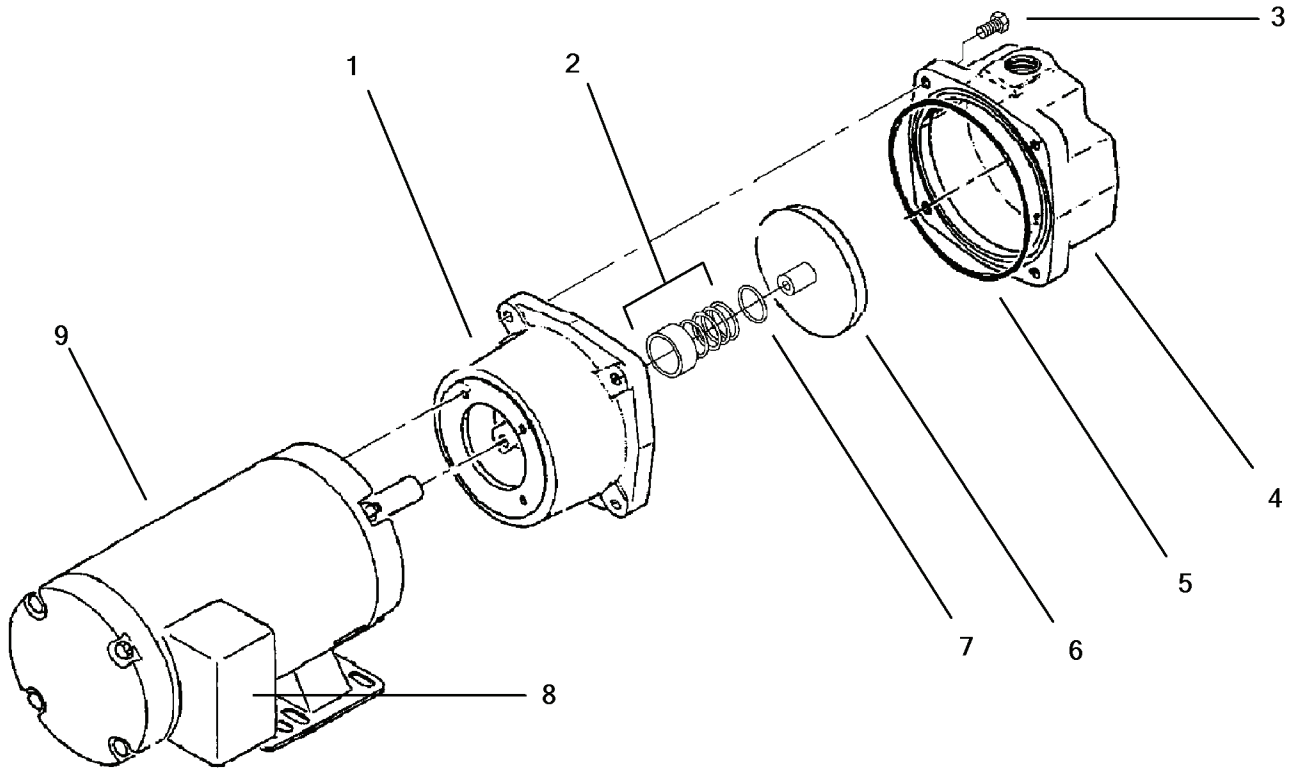

Figure 2-6 Distillate Pump Assembly.

2-14. Distillate Dump Valve. (Figure 2-7)

This task covers: a. Inspect, b. Repair, c. Replacement.

INITIAL SETUP

Tools

Tool Kit, General Mechanic's,
5180-00-699-5273

Equipment Condition

TM 55-1905-223-10, Waste Heat Evaporator
shutdown and tagged "Out of Service - Do Not
Operate" (FM 55-502).

Materials/Parts

Spare Parts Kit, P/N 93077-89
Goggles, Item 7, Section II, Appendix C
Grease, Silicone Insulated Electr, Item 8, Section II
Appendix C
Warning Tag, Item 17, Section II, Appendix C
Wiping Rags, Item 19, Section II, Appendix C

INSPECT

Inspection of the Distillate Dump Valve is accomplished through Preventive Maintenance Checks and Services (PMCS, TM 55-1905-223-10).

WARNING

Always ensure affected circuits have been secured, locked out and tagged out. Performing maintenance with circuits energized may result in death or injury to personnel or equipment damage.

WARNING

A high salinity reading directed to the freshwater storage tank will contaminate freshwater supply and consumption is hazardous. Discharge of distillate overboard will reduce freshwater supply.

CAUTION

Do not attempt distillate dump valve maintenance without first removing from piping group.

REMOVAL

- a. To remove the distillate dump valve perform distillate piping group removal procedures a and c (Paragraph 2-12).

WARNING

The retaining clip is under tension and may spring upward when released. Use goggles for eye protection.

- b. Remove retaining clip (2), or retaining cap (1), and slide nameplate (3) back away from junction box utilizing pry spot. Slide coil assembly (24) up and off of the solenoid base subassembly (23).
- c. Remove pin bearing screw (12) and pin bearing gasket (11).

- d. Remove solenoid base subassembly (23) from valve body (10), and remove end cap (20) with end cap gasket (18). Slide core/spring subassembly (22) and bonnet gasket (21) from valve lever (19) and set aside.

WARNING

The disc guide caps are under tension from the upper and lower springs and may spring upward. Use goggles for eye protection.

- e. Remove the upper disc guide cap (5) with disc guide cap gasket (9) to remove the strong spring (6), upper valve disc (7) and upper valve seat (8).
- f. Remove the lower disc guide cap (16) with disc guide cap gasket (17) to remove the weak spring (15), lower valve disc (14) lower valve seat (13) and valve lever (19).

REPAIR

Repair of the distillate dump valve consists of replacing the coil and any other worn or damaged components utilizing parts kit.

NOTE

Lubricate all O-rings and gaskets with a suitable silicone grease.

REPLACEMENT

- a. Install valve lever (19) and secure by installing the pin bearing gasket (11) and pin bearing screw 12).
- b. Replace the lower valve seat (13), lower valve disc (14), the weak spring (15) and the lower disc guide cap (16) with disc guide cap gasket (17). Torque to 185 inch pounds +/- 15.
- c. Replace the upper valve seat (8) upper valve disc (7), strong spring (6) and the upper disc guide cap (5) with disc guide cap gasket (9). Torque to 185 inch pounds +/- 15.
- d. Slide core/spring subassembly (22) and bonnet gasket (21) onto valve lever (19) and replace end cap (20) and end cap gasket (18), replace solenoid base subassembly (23) onto valve body (10) and torque to 175 inch pounds +/- 25.
- d. Slide coil assembly (24) on the solenoid base subassembly (23). Replace nameplate (3) and retaining clip (2), or retaining cap (1).
- e. Perform distillate piping group replacement procedures (Paragraph 2-12).
- f. Restore electrical power, start the Evaporator, and conduct operational check (Paragraph 2-6.c).
- g. Operate the WHE (Paragraph 2-6.c) and check covers, gaskets, piping and hoses for leaks, correct as necessary.

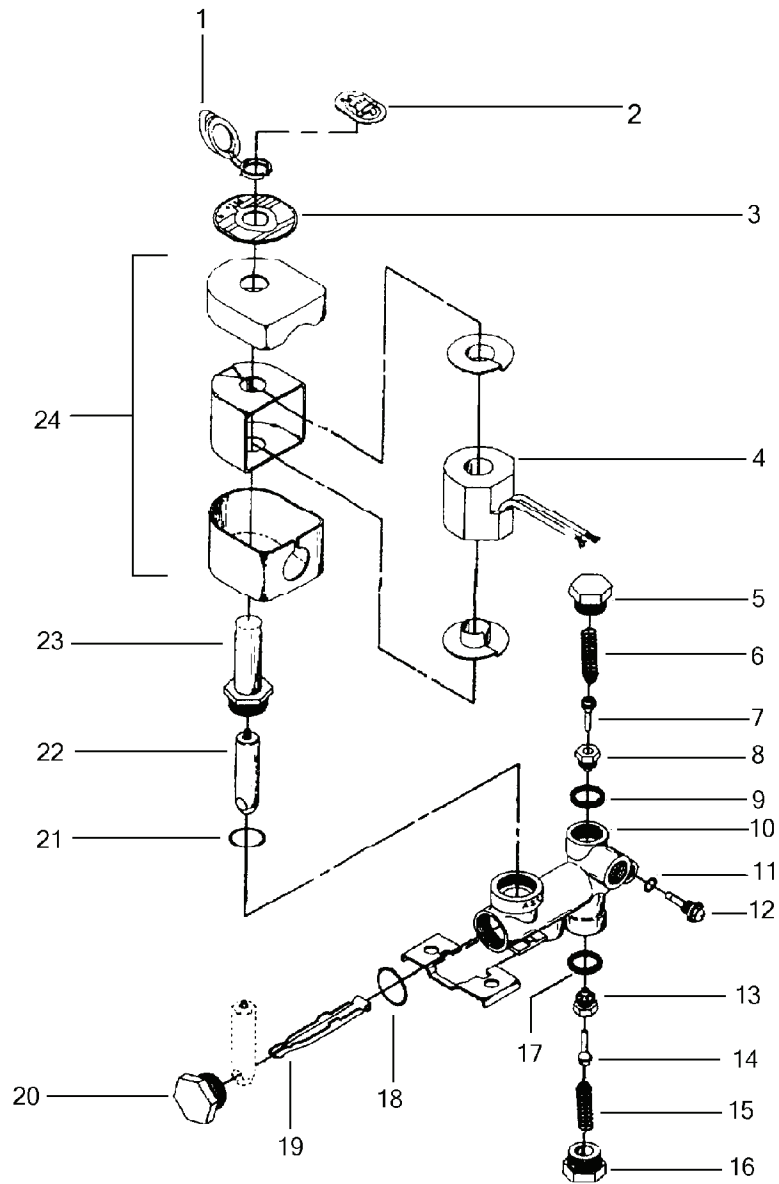

Figure 2-7. Distillate Dump Valve.

2-15. Ultraviolet (UV) Sterilizer. (Figure 2-8)

This task covers: a. Inspect, b. Service, c. Repair.

INITIAL SETUP

Tools

Tool Kit, General Mechanic's,
5180-00-699-5273

Equipment Condition

TM 55-1905-223-10, Waste Heat Evaporator
and UV Sterilizer shutdown and tagged
"Out of Service - Do Not Operate" (FM 55-502).

Materials/Parts

Power Supply, P/N 6240UD
Ultraviolet Lamp, P/N 8050SUD
O-ring, P/N 1090UD
Warning Tag, Item 18, Section II, Appendix C
Wiping Rags, Item 19, Section II, Appendix C

INSPECT

Inspection of the UV Sterilizer is accomplished through Preventive Maintenance Checks and Services (PMCS, TM 55-1905-223-10).

WARNING

Always ensure affected circuits have been secured, locked out and tagged out. Performing maintenance with circuits energized may result in death or injury to personnel or equipment damage.

SERVICE

Service of the UV sterilizer consists of changing the UV Lamp and Filter annually as described in Preventive Maintenance Checks and Services (PMCS), Table 2-1.

REMOVAL

- a. Shut the valves (supply and discharge) on each side of the UV sterilizer.
- b. Turn local UV sterilizer switch to OFF position, and unplug power supply (1) from receptacle.

CAUTION

UV lamp is very fragile, handle with care. Be sure there are no marks or fingerprints on the UV Lamp. Clean with denatured alcohol and cotton if necessary.

- c. Remove the UV lamp (8) by removing the clamp and cover and gently pulling up and out of the chamber. Gently remove UV lamp from socket and set aside.
- d. Remove quartz nipple (11) by unscrewing from head assembly (7).

- e. Remove the quartz sleeve (2), stainless steel washer (10) and O-ring (9) from the chamber.
- f. Remove the chamber (4) and carbon filter (3) from the head assembly (7) by loosening the clamp (5) and unscrewing the chamber from the head.

NOTE

Removal of the head assembly is not necessary unless damaged or unserviceable.

- g. To remove the head assembly (7) disconnect inlet and outlet couplings of U/V sterilizer and four bolts from bracket.

WARNING

Testing the UV lamp (8) should be accomplished only by trained personnel. Hazardous light emissions and power output exist in this system.

REPAIR

Repair of the UV sterilizer consists of replacing the lamp and any worn, damaged or deteriorated components.

REPLACEMENT

- a. To replace the head assembly (7) secure in position with four bolts and reconnect the inlet and outlet couplings.
- b. Install chamber (4) with carbon filter (3) onto head assembly (7) and tighten clamp (5).
- c. Replace stainless steel washer (10) and O-ring (9) onto the quartz sleeve (2) and gently slide into head assembly (7).
- d. Replace quartz nipple (11) onto head assembly (7) by screwing on hand tight only.
- e. Replace UV lamp into socket and gently slide the UV lamp (8) through the quartz nipple (11) into the head assembly and secure with cover and clamp.
- f. Plug power supply (1) into UV sterilizer receptacle. Turn U/V sterilizer switch to on. Ensure green power light is illuminated.
- g. Open valves (supply and discharge) on each side of the UV sterilizer.
- h. Restore electrical power, start the Evaporator, and conduct operational check (Paragraph 2-6.c).
- i. Operate the WHE (Paragraph 2-6.c) and check covers, gaskets, piping and hoses for leaks, correct as necessary.

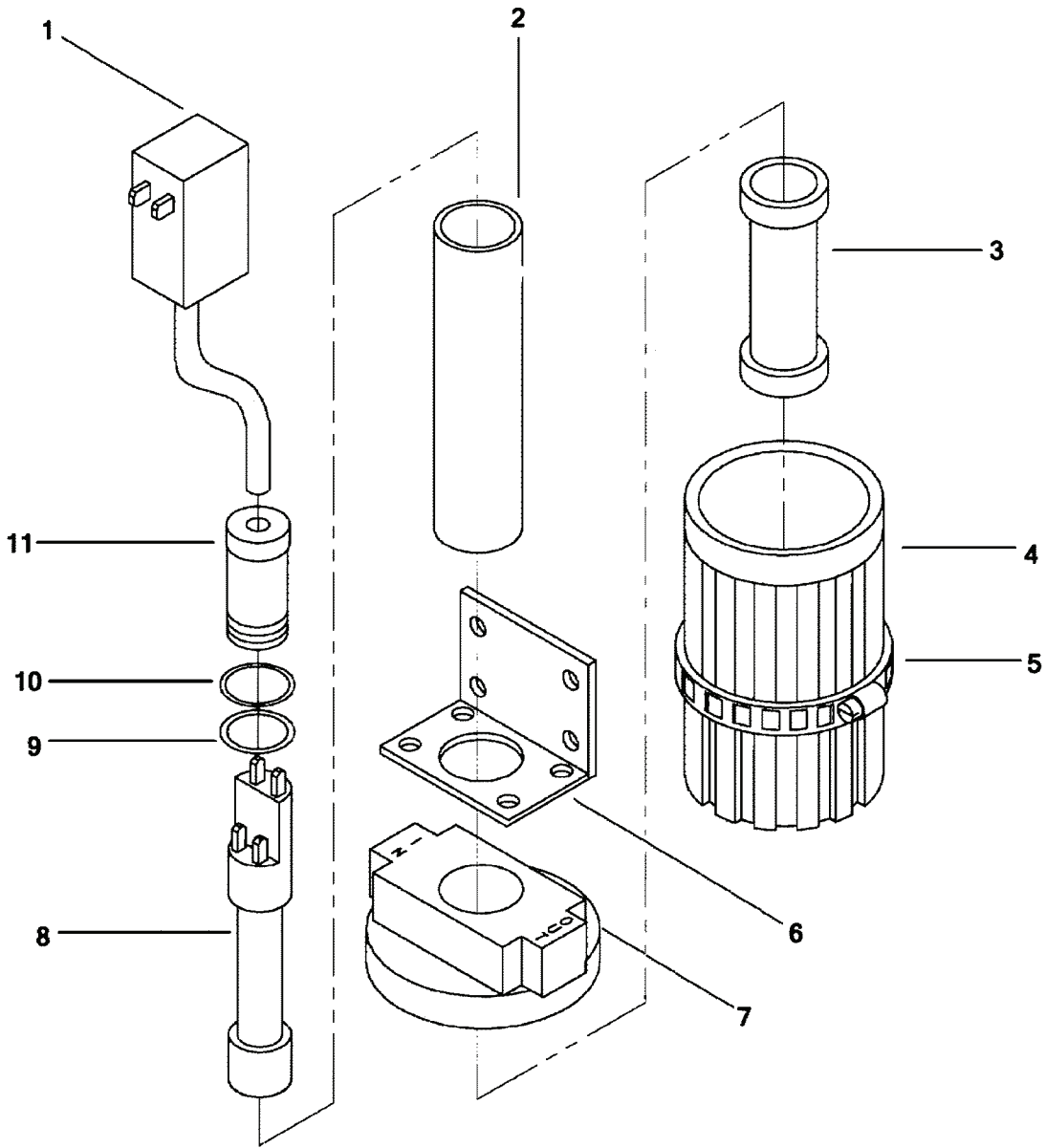

Figure 2-8. Ultraviolet (UV) Sterilizer.

2-16. Product Water Flow Meter. (Figure 2-9)

This task covers: a. Inspect, b. Replacement.

INITIAL SETUP**Tools**

Tool Kit, General Mechanic's,
5180-00-699-5273

Equipment Condition

TM 55-1905-223-10, Waste Heat Evaporator
shutdown and tagged "Out of Service - Do Not
Operate" (FM 55-502).

Materials/Parts

Warning Tag, Item 18, Section II , Appendix C
Wiping Rags, Item 19, Section II, Appendix C

NOTE

Inspection of the product water flow meter must be conducted during WHE operation.

INSPECT

- a. With Evaporator operating inspect product water meter for leaks or damage.
- b. When Evaporator is making good water, ensure register is measuring the amount of product output.

WARNING

Always ensure affected circuits have been secured, locked out and tagged out. Performing maintenance with circuits energized may result in death or injury to personnel or equipment damage.

REMOVAL

To remove the Product Water Flow Meter (4, Figure 2-9); loosen the inlet and outlet couplings and remove from distillate piping group.

REPLACEMENT

To replace the Product Water Flow Meter (4), install into the distillate piping group and tighten the inlet and outlet couplings.

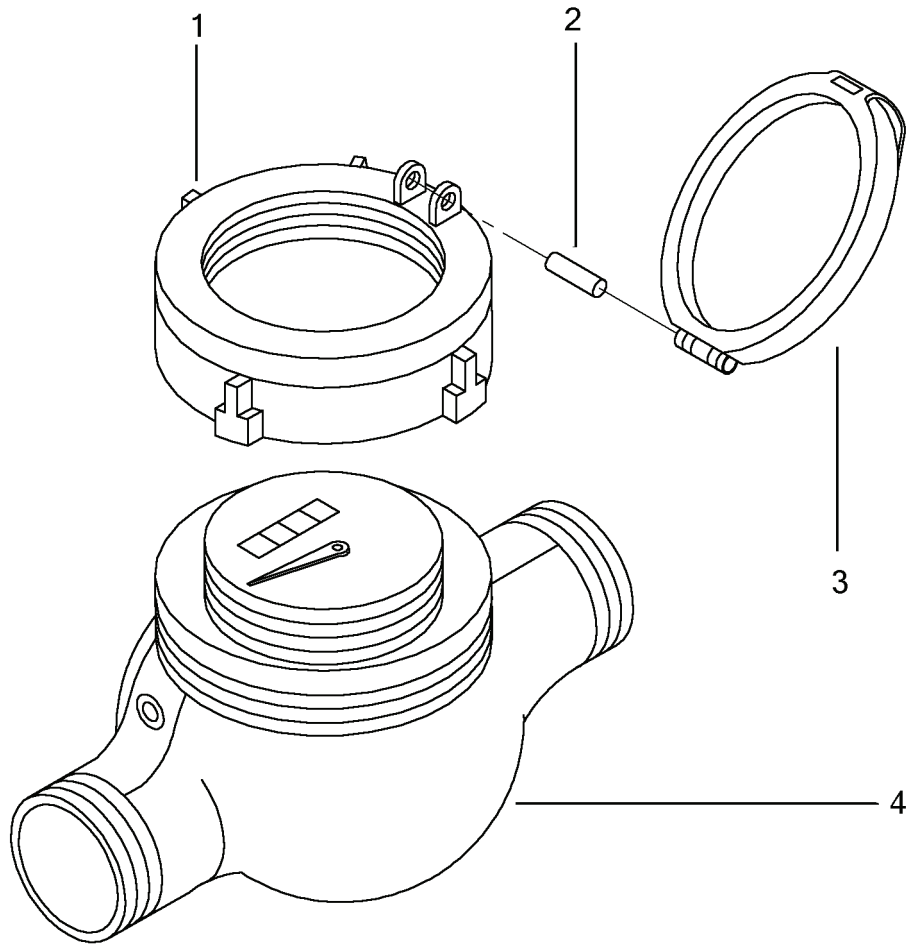

Figure 2-9. Product Water Flow Meter.

2-17. Jacket Water Piping Group. (Figures 2-1 and 2-10)

This task covers: a. Repair.

INITIAL SETUP
Tools

Tool Kit, General Mechanic's,
5180-00-699-5273
Tool Kit, Welder's,
5180-00-754-0661
Torch Outfit, Cutting and Welding
Medium Duty, Oxygen and Acetylene,
3433-00-357-8116

Equipment Condition

TM 55-1905-223-10, Waste Heat Evaporator
shutdown and tagged "Out of Service - Do Not
Operate" (FM 55-502).

Materials/Parts

Gloves, Chemical, Item 6, Section II, Appendix C
Goggles, Item 7, Section II, Appendix C
Pail, Utility Item 12, Section II, Appendix C
Teflon Tape, Item 16, Section II, Appendix C
Warning Tag, Item 18, Section II, Appendix C
Wiping Rags, Item 19, Section II, Appendix C

WARNING

Always ensure affected circuits have been secured, locked out and tagged out. Performing maintenance with circuits energized may result in death or injury to personnel or equipment damage.

WARNING

Use protective gloves and safety glasses when working on or around jacket water piping.

WARNING

If the seawater heater bundle is suspected of being damaged then the seawater reservoir shall be treated as containing hazardous material. Personal Protective Equipment (PPE) must be worn to avoid contact with skin and splashing in eyes.

CAUTION

Ensure compliance with Federal and international laws prior to overboard discharge of hazardous materials.

CAUTION

When handling the tube bundles, extreme care should be exercised to prevent damage to the tubes. Do not allow tubes to support the weight of the bundle. Damage will occur due to thin wall tube construction.

NOTE

Some piping and piping connections are welded assemblies and a cutting and welding torch kit is required. All parts must be manufactured from the same material. Refer to TB-55-1900-204-24 (Welding on Watercraft).

REMOVAL

a. Removal of the jacket water piping group (Figure 2-10), proceed as follows:

- (1) Ensure the jacket water pump discharge (1) and supply (11) valves and the seawater supply (ESW-5) (Figure 2-1) valve are closed.

CAUTION

Ensure compliance with Federal and international laws prior to overboard discharge of hazardous materials.

- (2) Drain the jacket water pump (12, Figure 2-10) and disconnect the pump outlet flange (13).

WARNING

If the seawater heater bundle is suspected of damage then the drainage must be contained in a suitable container. Personal Protective Equipment (PPE) must be worn to avoid contact with skin and splashing in eyes.

- (3) Place a bucket under the Evaporator and drain. Drain the seawater reservoir by removing drain plug from under Evaporator.
- (4) Place a bucket under union fittings (7) to catch remaining jacket water.
- (5) Loosen the fittings to allow piping to drain in container.
- (6) Remove union fittings (7) and disconnect associated piping.
- (7) Mark the position of the bonnet in the WHE to ensure original position installation or correct new bundle installation.
- (8) Remove the eight bolts (5) from bonnet (10), and remove bonnet and rib gasket (4).

CAUTION

When handling the tube bundles, extreme care should be exercised to prevent damage to the tubes. Do not allow tubes to support the weight of the bundle. Damage will occur due to thin wall tube construction.

- (9) Gently remove seawater heater bundle (3) and ring gasket (2).
- b. Removal procedures for the seawater heater bundle supply thermometer (9) and discharge thermometer (8) are the same:
- (1) Remove the thermometers by unscrewing from the elbow pipe connections.

c. Removal of the braided pipe connector (15) and associated piping can be accomplished after completing procedures a.1 through a.6.

CAUTION

When handling the tube bundles, extreme care should be exercised to prevent damage to the tubes. Do not allow tubes to support the weight of the bundle. Damage will occur due to thin wall tube construction.

NOTE

Apply Teflon Tape to all threaded fittings.

REPAIR

Repair is by replacement of the gaskets (2 or 4), the seawater heater bundle (3), seawater heater supply (9) and discharge (8) thermometers and damaged or worn associated piping (Figure 2-10):

- a. To repair the seawater heater bundle (3):
 - (1) Remove seawater heater bundle as described in removal procedures a.
 - (2) Install new seawater heater bundle as described in replacement procedures.
- b. To repair associated pipe fittings:
 - (1) Remove applicable associated pipe fittings as describe in removal procedure a and c.
 - (2) Install new applicable pipe fitting as described in replacement procedures.

CAUTION

When handling the tube bundles, extreme care should be exercised to prevent damage to the tubes. Do not allow tubes to support the weight of the bundle. Damage will occur due to thin wall tube construction.

NOTE

Some piping and piping connections are welded assemblies and a cutting and welding torch kit is required. All parts must be manufactured from the same material. Refer to TB-55-1900-204-24 (Welding on Watercraft).

NOTE

Apply Teflon Tape to all threaded fittings.

REPLACEMENT

- a. Replace the braided pipe connector (15) and associated piping.
- b. To replace the jacket water piping group (Figure 2-10), proceed as follows:

CAUTION

When handling the tube bundles, extreme care should be exercised to prevent damage to the tubes. Do not allow tubes to support the weight of the bundle. Damage will occur due to thin wall tube construction.

NOTE

When installing a new heater bundle ensure the orientation of the original marked bundle are the same.

- (1) Gently install seawater heater bundle (3) and ring gasket (2).
 - (a) When installing a new heater bundle ensure the orientation of the original marked bundle is the same.

- (2) Replace the rib gasket (4) and bonnet (10), securing with eight bolts (5).
- (3) Reconnect all associated piping and union fittings (7).
- c. Reconnect the pump (12) and discharge flange (13).
- d. Replace the seawater heater supply (9) and discharge (8) thermometers.
- e. Restore electrical power, start the Evaporator, and conduct operational check (Paragraph 2-6.c).
- f. Operate the WHE (Paragraph 2-6.c) and check covers, gaskets, piping and hoses for leaks, correct as necessary.

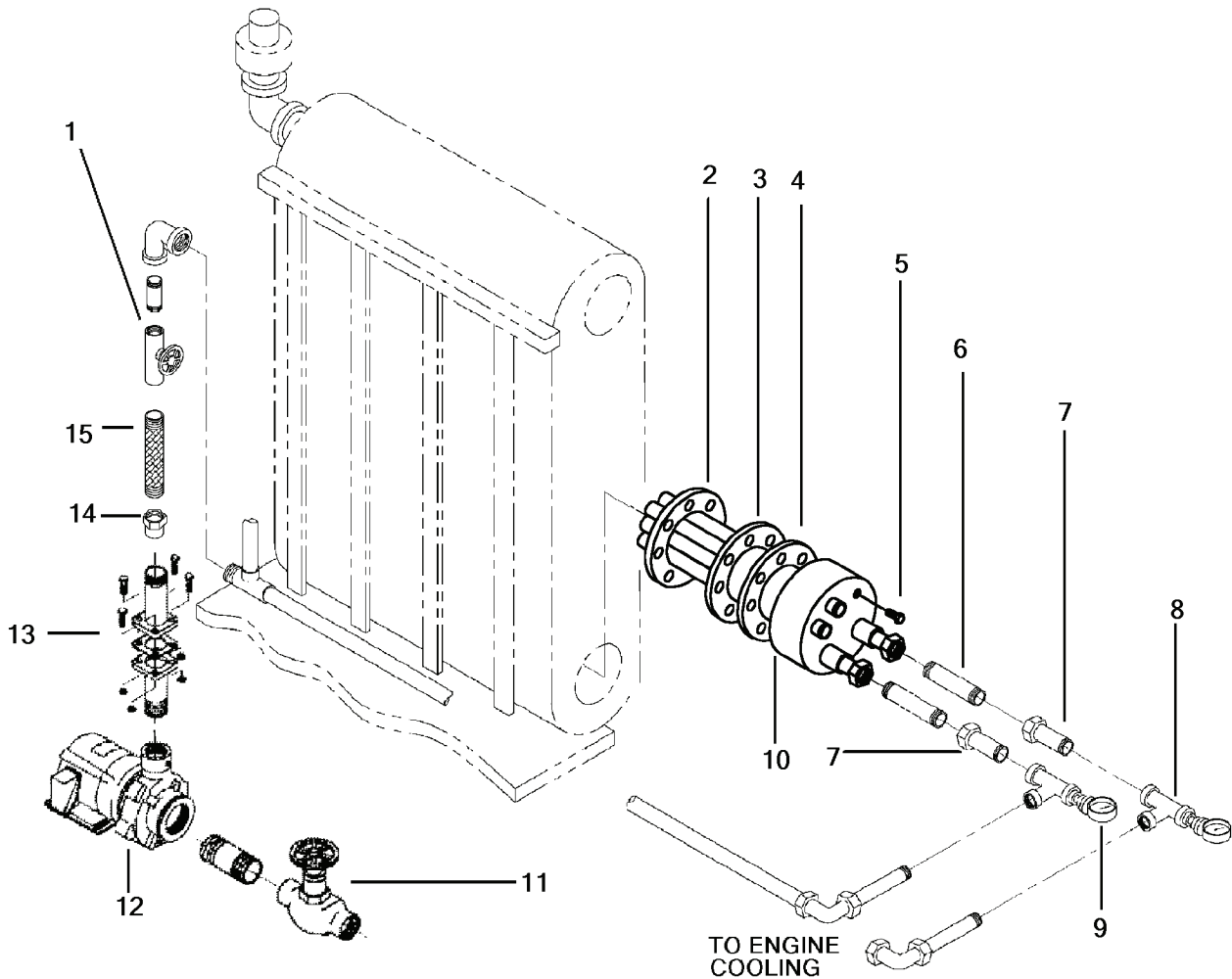

Figure 2-10. Jacket Water Piping Group.

2-18. Jacket Water Pump Assembly. (Figure 2-11)

This task covers: a. Inspect, b. Repair, c. Replacement.

INITIAL SETUP

Tools

Tool Kit, General Mechanic's,
5180-00-699-5273
Tool Kit, Electrician's
5180-00391-1087
Strap Wrench, Item 15, Section II, Appendix C
Torque Wrench, Item 17, Section II, Appendix C

Equipment Condition

Jacket Water Piping Bypassing Boost Pump
TM 55-1905-223-10, Waste Heat Evaporator
shutdown and tagged "Out of Service - Do Not
Operate" (FM 55-502).

Materials/Parts

Mechanical Seal, P/N 712-1004-749
Impeller, P/N 441792225
Gasket, P/N 364-0452-457
Antiseize Compound, Item 3, Section II, Appendix C
Motor Oil, Item 9, Section II, Appendix C
Pail, 5 gallon, Item 11, Section II, Appendix C
Warning Tag, Item 18, Section II, Appendix C
Wiping Rags, Item 19, Section II, Appendix C

INSPECT

Inspection of the jacket water pump is accomplished through Preventive Maintenance Checks and Services (PMCS, TM 55-1905-223-10).

WARNING

Always ensure affected circuits have been secured, locked out and tagged out. Performing maintenance with circuits energized may result in death or injury to personnel or equipment damage.

WARNING

Use protective gloves and safety glasses when working on or around jacket water piping. Avoid splashing in eyes when disconnecting lines.

CAUTION

Ensure compliance with Federal and International laws prior to disposal of Hazardous Materials.

REMOVAL

To remove Jacket Water Pump (Figure 2-11), proceed as follows:

- a. Remove conduit box cover (20).
- b. Tag and disconnect wires in conduit box (20) to ensure proper motor rotation after installation.
 - (1) Proper motor rotation is counterclockwise facing shaft end.

CAUTION

Ensure compliance with Federal and international laws prior to overboard discharge of hazardous materials.

- c. Remove pipe plugs (5 and 8), and drain jacket water into a suitable container.
- d. Disconnect inlet and outlet lines from casing (9).
- e. Remove casing (9) by removing capscrews (10).
 - (1) Note the condition of gasket (7) which adheres either to the casing (9) or the bracket (6), retain or replace as necessary.
- f. Remove case wearing ring (16) from impeller (11).
- g. Remove impeller screw (15) and washer (14) from the shaft by turning in a counterclockwise direction.
 - (1) A screwdriver slot on motor shaft opposite the pump is provided for steadying the shaft.
 - (a) Use of a strap wrench is recommended to avoid marring the impeller (11).
 - (b) Remove impeller (11) from shaft by sliding off woodruff key (16).
 - (c) File or polish out wrench marks from the impeller (11) before reusing.
- h. Remove rotating components (14 and 15) of mechanical seal (12) from shaft (21) extension.
 - (1) If the flexible diaphragm or bellows (part of 14) stick tightly, either component may be lubricated with oil or cut away with a knife.
- i. The stationary seat (13) and cup gasket or O-ring (parts of 15) may be removed with a wire hook (coat hanger wire).
 - (1) Insert hook between inside diameter of seat (13) and shaft (21), and pull forward. Otherwise, casing (9) may be removed and seat pushed out.
- j. Remove bolts (4) and washers (3) from pump bracket (6), and remove pump bracket (6) and spacer (2) from motor (1).
- k. Remove foundation bolts and nuts securing the motor (1).

CAUTION

Care should be observed that cleansing material and oil are free of foreign particles.

CAUTION

Do not use grease or allow grease on the sealing surfaces.

NOTE

Apply Teflon Tape to all threaded fittings.

REPAIR

- a. Repair of the jacket water pump (1) is by replacement of the mechanical seal (12), impeller (11), gasket (7) and O-ring (part of 15).

- b. The complete mechanical seal (12), both stationary (13) and rotating members (14 and 15), will be replaced whenever there is any leakage at the shaft (21) or whenever the pump is dismantled to the point of separating the primary seal ring (part of 14) and stationary seat (13).
- c. Repair to the jacket water pump motor is by replacement.

REPLACEMENT

To replace the Jacket Water Pump (Figure 2-11), proceed as follows:

- a. Place motor (1) on foundation.
- b. Align motor feet bolt holes over bolt holes in foundation and insert mounting bolts with nuts.
- c. Install spacer (2) and pump bracket (6) to motor (1) with bolts (4) and washers (3).
- d. Finger press stationary seat (13) with its rubber cup or O-ring (part of 13) into position in the counter bore of the casing (9).
 - (1) Apply uniform pressure to ensure that the seat assembly is perpendicular to the shaft when in position.

CAUTION

Care should be observed that cleansing material and oil are free of foreign particles.

Do not use grease or allow grease on the sealing surfaces. Avoid skin contact on mating surfaces of mechanical seal (12).

- e. Clean the polished face of the stationary seat (13) with a lint free cloth or tissue, and lightly coat this surface with an SAE-10 or equivalent oil.

CAUTION

Do not continue to slide the assembly down the shaft once the rotating assembly has engaged the spring. Inspect the carbon sealing face, and remove any foreign particles with a lint-free cloth or tissue.

Do not use grease or allow grease on the sealing surfaces. Avoid skin contact on mating surfaces of mechanical seal (12).

- f. Replace the carbon rotating subassembly (14) of the mechanical seal (12) with O-ring (part of 15) on the shaft-like extension of the impeller (11).
 - (1) Lightly oil (SAE-10) the mechanical seal (12) to facilitate installation of the bellows or diaphragm (part of 14).
 - (2) Drop spring retainer and spring assembly (parts of 15) over the impeller shaft.
 - (3) Press the carbon rotating subassembly (14), consisting of primary seal ring, bellows or diaphragm, seal cage, and drive band, down the impeller shaft until it engages, but does not compress the open end of the spring.
- g. Thoroughly clean gasket (7) sealing surfaces with a clean cloth.
- h. Install the impeller (11) with mechanical seal (12) on the shaft (21).
 - (1) Lubricate inside diameter of impeller (11) with antiseize. Do not lubricate the shaft (21).

- (2) Place woodruff key (13) onto shaft (21), and align the impeller (11) onto the woodruff key (13) and slide the impeller (11) onto the shaft.
 - (3) Install and tighten impeller screw (15) with washer (14) into shaft, utilizing a flat tipped screwdriver in the slot on the opposite end to steady the shaft and tighten to 22 to 25 foot-pounds.
- i. Install case wearing ring (16) into impeller (11).
 - j. Inspect the casing (9) and gasket (7) surfaces for cleanliness. Remove all foreign matter so that gaskets (7) will have a proper seal.
 - k. Install the casing (9) and gasket (7), secure with capscrews (10).
 - l. Connect wires in conduit box (2) as tagged on removal to ensure proper motor rotation.
 - (1) Proper motor rotation is counterclockwise facing shaft end.
 - (2) If motor rotation is not counterclockwise reverse any two incoming power leads.
 - m. Install conduit box cover (17).
 - n. Visually check the motor, pump and connections for leaks. Correct as necessary.
 - o. Restore electrical power, start the Evaporator, and conduct operational check (Paragraph 2-6.c).
 - p. Operate the WHE (Paragraph 2-6.c) and check covers, gaskets, piping and hoses for leaks, correct as necessary.

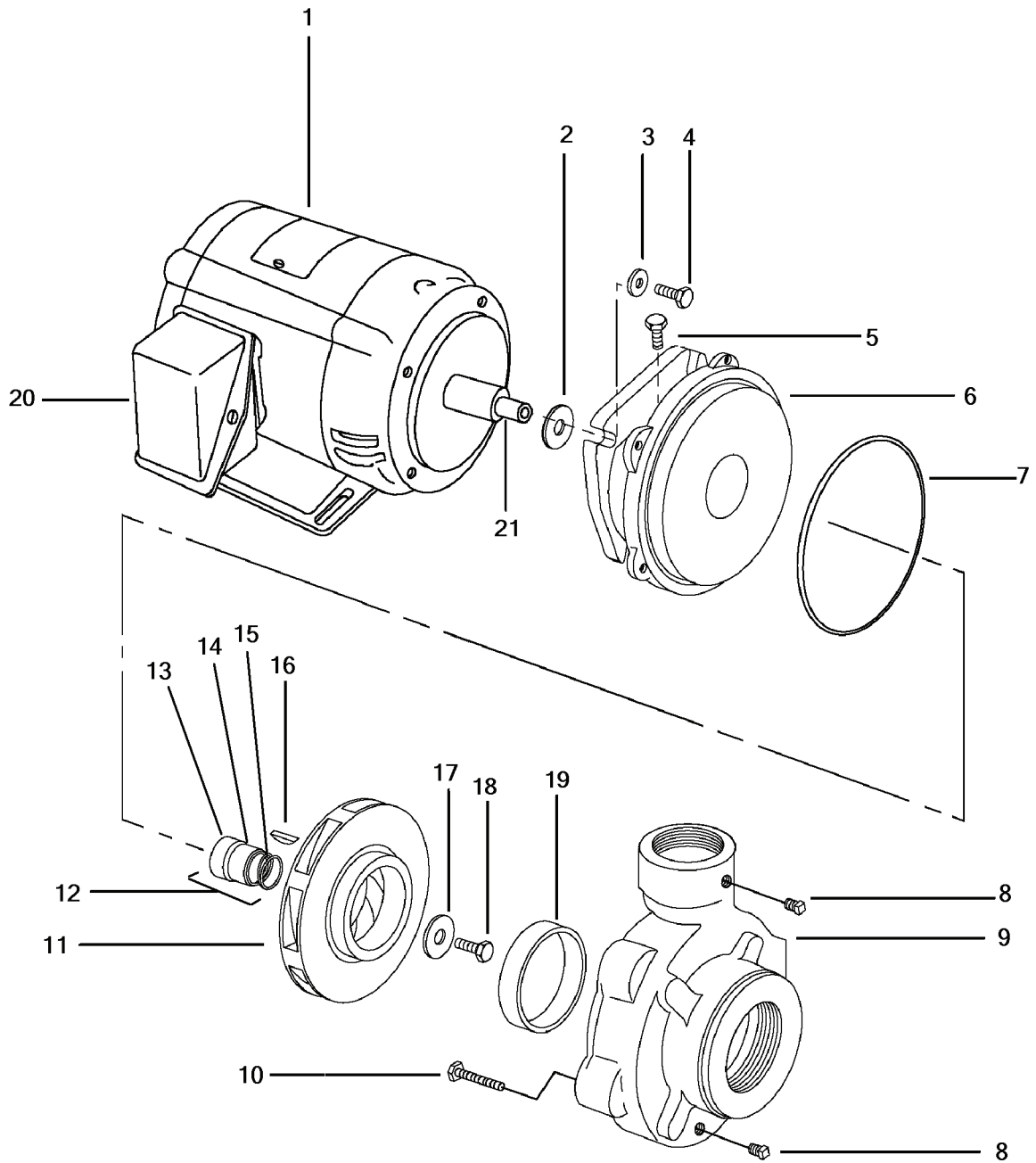

Figure 2-11. Jacket Water Pump.

2-19. Feed Water Piping Group. (Figure 2-12)

This task covers: a. Service, b. Repair.

INITIAL SETUP

Tools

Tool Kit, General Mechanic's,
5180-00-699-5272
Tool Kit, Welder's,
5180-00-754-0661
Torch Outfit, Cutting and Welding
Medium Duty, Oxygen and Acetylene,
3433-00-357-8116

Equipment Condition

TM 55-1905-223-10, Waste Heat Evaporator
shutdown and tagged "Out of Service - Do Not
Operate" (FM 55-502).

Materials/Parts

Detergent, Item 5, Section II, Appendix C
Pail, Utility Item 12, Section II, Appendix C
Scrub Brush, Item 14, Section II, Appendix C
Teflon Tape, Item 16, Section II, Appendix C
Warning Tag, Item 18, Section II, Appendix C
Wiping Rags, Item 19, Section II, Appendix C

WARNING

Always ensure affected circuits have been secured, locked out and tagged out. Performing maintenance with circuits energized may result in death or injury to personnel or equipment damage.

CAUTION

When handling the tube bundles, extreme care should be exercised to prevent damage to the tubes. Do not allow tubes to support the weight of the bundle. Damage will occur due to thin wall tube construction.

NOTE

Some piping and piping connections are welded assemblies and a cutting and welding torch kit is required. All parts must be manufactured from the same material. Refer to TB-55-1900-204-24 (Welding on Watercraft).

REMOVAL

- a. Removal of the piping group (Figure 2-12), proceed as follows:
 - (1) Place container under wye strainer (16) to catch remaining feed water.
 - (2) Remove cap (14) and strainer basket (15) and allow draining of piping system.
 - (3) Place container under brine jet pump (22) to catch remaining feed water.

- (4) Loosen the brine jet pump (22) union fitting (1) to drain remaining water from piping.
 - (5) Disconnect the six union fittings (1) and remove the piping group.
 - (6) Remove the feed orifice (11) from Waste Heat Evaporator shell and ball valve (12) from fitting (13) after the piping group is clear.
- b. Removal procedures for the Vacuum Jet Pump (2) connected to treaded piping, and the Brine Jet Pump (22) connected to a male/male coupling (18) are the same, (Figure 2-11), proceed as follows:
- (1) After the piping group is removed the jet pumps (2 or 22) can be removed by disconnecting from the appropriate piping.
 - (2) Remove the jet pump nozzles (21 or 23) by unscrewing from the jet pumps.
- c. Removal of the Freshwater Condenser Bundle (5) can only be accomplished after steps a.1 through a.5 have been completed.
- (1) With the piping group clear, disconnect the seawater supply union fitting.

CAUTION

When handling the tube bundles, extreme care should be exercised to prevent damage to the tubes. Do not allow tubes to support the weight of the bundle. Damage will occur due to thin wall tube construction.

- (2) Remove the eight bolts (7) from bonnet (10), and remove bonnet and rib gasket (6).
 - (3) Mark the position of the bonnet in the WHE to ensure original position installation or correct new bundle installation.
 - (4) Gently remove the freshwater condenser bundle (5) and ring gasket (4).
- d. Removal of the Sight Glass (19), proceed as follows:
- (1) Remove the three nuts from the sight glass.
 - (2) Remove the sight glass and gasket (20).
- e. To remove the compound gauge (3), and the vacuum release valve (17), proceed as follows:
- (1) Disconnect the compound gauge from piping.
 - (2) Remove the piping and disconnect the vacuum release valve from the Evaporator.
- f. To remove the pressure gauge (8) or temperature gauges (9 or 24).
- (1) Disconnect the pressure gauge (8) or temperature gauges (9 or 24) from the appropriate fitting.

SERVICE

- a. Service procedures to the Vacuum Jet Pump (2) and the Brine Jet Pump (22) are the same; procedures for one are as follows:
- (1) Remove the pump from the piping group (Removal procedures a. and b.).
 - (2) Remove the nozzle (21 or 23) from the pump, ensure it is unclogged and free of debris, clean with soapy water.

- (3) Rinse with clean potable water.
- b. Service to the Wye strainer (16) is as follows:
- (1) Remove wye strainer cap (14).
 - (2) Remove strainer basket (15) from wye strainer, ensure it is unclogged and free of debris, clean with soapy water.
 - (3) Rinse with clean potable water.

CAUTION

When handling the tube bundles, extreme care should be exercised to prevent damage to the tubes. Do not allow tubes to support the weight of the bundle. Damage will occur due to thin wall tube construction.

NOTE

Some piping and piping connections are welded assemblies and a cutting and welding torch kit is required. All parts must be manufactured from the same material. Refer to TB-55-1900-204-24 (Welding on Watercraft).

NOTE

Apply Teflon Tape to all threaded fittings.

REPAIR

Repair is by replacement of the Jet Pumps (2 or 22), Feed Orifice (11), Freshwater Condenser Bundle (5), pressure gauge (8), temperature gauges (9 or 24) and damaged or worn associated piping (Figure 2-12):

- a. To repair associated pipe fittings
 - (1) Remove applicable associated pipe fittings as describe in removal procedure a.
 - (2) Install new applicable pipe fitting as described in replacement procedures.

CAUTION

When handling the tube bundles, extreme care should be exercised to prevent damage to the tubes. Do not allow tubes to support the weight of the bundle. Damage will occur due to thin wall tube construction.

NOTE

Some piping and piping connections are welded assemblies and a cutting and welding torch kit is required. All parts must be manufactured from the same material. Refer to TB-55-1900-204-24 (Welding on Watercraft).

NOTE

Apply Teflon Tape to all threaded fittings.

REPLACEMENT

- a. To replace the Freshwater Condenser Bundle (5), proceed as follows:

NOTE

When installing a new freshwater condensor bundle, ensure the orientation of the original marked bundle are the same.

- (1) Replace the ring gasket (4), and gently install the bundle.
 - (a) When installing a new fresh water condensor bundle, ensure the orientation of the original marked bundle are the same.
 - (2) Replace the rib gasket (6) and bonnet (10), secure with the eight bolts (7).
 - (3) Reconnect the seawater inlet union fittings.
- b. To replace the Vacuum Jet Pump (2) and the Brine Jet Pump (22) proceed as follows:
- (1) Install the jet pump nozzles (21 or 23) into the jet pumps.
 - (2) Reconnect the appropriate piping.
- c. To replace the piping group (Figure 2-12), proceed as follows:
- (1) Replace the feed orifice (11) into the Waste Heat Evaporator shell, and the ball valve (12) into fitting (13).
 - (2) Place the piping group into position.
 - (3) Connect all six union fittings (1) and tighten.
 - (4) Replace the strainer basket (15) and cap (14).
- d. To replace the Sight Glass (19), proceed as follows:
- (1) Install gasket (20) and glass.
 - (2) Replace the three nuts and tighten.
- e. To replace the compound gauge (3), and the vacuum release valve (17), proceed as follows:
- (1) Reconnect the vacuum release valve to the Evaporator and associated piping.
 - (2) Reconnect the compound gauge to the piping.
- f. To replace the pressure gauge (8) or temperature gauges (9 or 24).
- (1) Reconnect the pressure gauge (8) or temperature gauges (9 or 24) to the appropriate fitting.
- g. Restore electrical power, start the Evaporator, and conduct operational check (Paragraph 2-6.c).
- h. Operate the WHE (Paragraph 2-6.c) and check covers, gaskets, piping and hoses for leaks, correct as necessary.

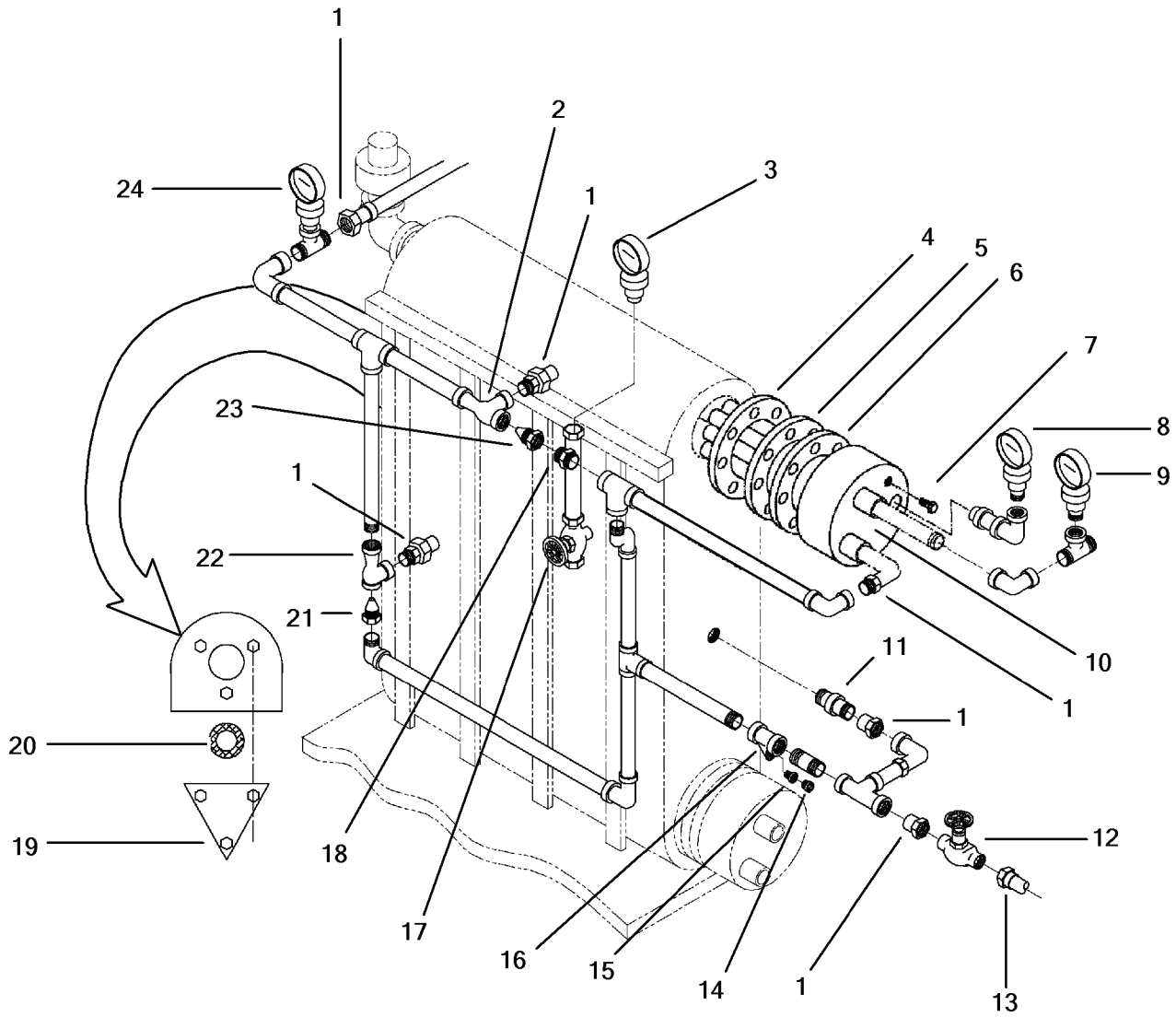

Figure 2-12. Feed Water Piping Group.

2-20. Relief Valve. (Figure 2-12 and 2-13)

This task covers: a. Replacement.

INITIAL SETUP**Tools**

Tool Kit, General Mechanic's,
5180-00-699-5273

Equipment Condition

TM 55-1905-223-10, Waste Heat Evaporator
shutdown and tagged "Out of Service - Do Not
Operate" (FM 55-502).

Materials/Parts

Teflon Tape, Item 16, Section II, Appendix C
Warning Tags, Item 18, Section II, Appendix C
Wiping Rags, Item 19, Section II, Appendix C

WARNING

Always ensure affected circuits or pipes have been secured, locked out and tagged out. Performing maintenance with circuits energized or pipes under pressure may result in death or injury to personnel or equipment damage.

WARNING

Use extreme care when breaking system connections. Escaping pressure and or fluids could cause injury.

REMOVAL

To remove the relief valve (Figure 2-13), proceed as follows:

- a. Open the vacuum release valve (17, Figure 2-12) to equalize internal pressure.
- b. Loosen the pipe coupling attached to the relief valve.
- c. Disconnect the piping from the relief valve.
- d. Remove the relief valve from the Evaporator by turning in a counterclockwise direction.

NOTE

Apply Teflon Tape to all threaded fittings.

REPLACEMENT

To replace the relief valve, proceed as follows (Figure 2-13):

- a. Install the relief valve on the Evaporator by turning in a clockwise direction.
- b. Connect the piping to the relief valve.
- c. Close the vacuum release valve (17, Figure 2-12).
- d. Restore electrical power, start the Evaporator, and conduct operational check (Paragraph 2-6.c).
- e. Operate the WHE (Paragraph 2-6.c) and check covers, gaskets, piping and hoses for leaks, correct as necessary.

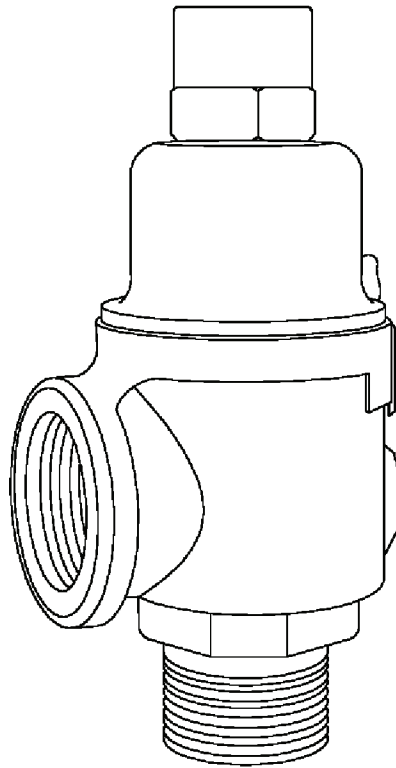

Figure 2-13. Relief Valve.

2-21. Gauge Panel. (Figure 2-14)

This task covers: a. Replacement.

INITIAL SETUP

Tools

Tool Kit, General Mechanic's,
5180-00-699-5273

Equipment Condition

TM 55-1905-223-10, Waste Heat Evaporator
shutdown and tagged "Out of Service - Do Not
Operate" (FM 55-502).

Materials/Parts

Gloves, Chemical, Item 6, Section II, Appendix C
Goggles, Item 7, Section II, Appendix C
Pail, Utility, Item 12, Section II, Appendix C
Warning Tags, Item 18, Section II, Appendix C
Wiping Rags, Item 19, Section II, Appendix C

WARNING

Always ensure affected circuits have been secured, locked out and tagged out. Performing maintenance with circuits energized may result in death or injury to personnel or equipment damage.

WARNING

Use protective gloves and safety glasses when working on or around jacket water or piping.

CAUTION

Ensure compliance with Federal and international laws prior to overboard discharge of hazardous materials.

REMOVAL

The procedures are the same for removal and replacement of the No. 1 Distillate Pump Discharge Pressure (1), No. 1 Jacket Water Pump Discharge Pressure (2), No. 2 Distillate Pump Discharge Pressure (4), and No. 2 Jacket Water Pump Discharge Pressure (3) gauges from the gauge panel (Figure 2-14).

- a. Place a suitable container under piping of gauge to be removed.
- b. Loosen the pipe coupling and allow pipe and gauge to drain.
- c. Disconnect the piping associated with gauge.
- d. Remove the three screws from the face plate and remove the gauge.

WARNING

Use protective gloves and safety glasses when working on or around jacket water or piping.

REPLACEMENT

Replacement procedures are the same for the four gauges:

- a. Install gauge and cover with three screws.
- b. Connect associated piping to the gauge.
- c. Restore electrical power, start the Evaporator, and conduct operational check (Paragraph 2-6.c).
- d. Operate the WHE (Paragraph 2-6.c) and check covers, gaskets, piping and hoses for leaks, correct as necessary.

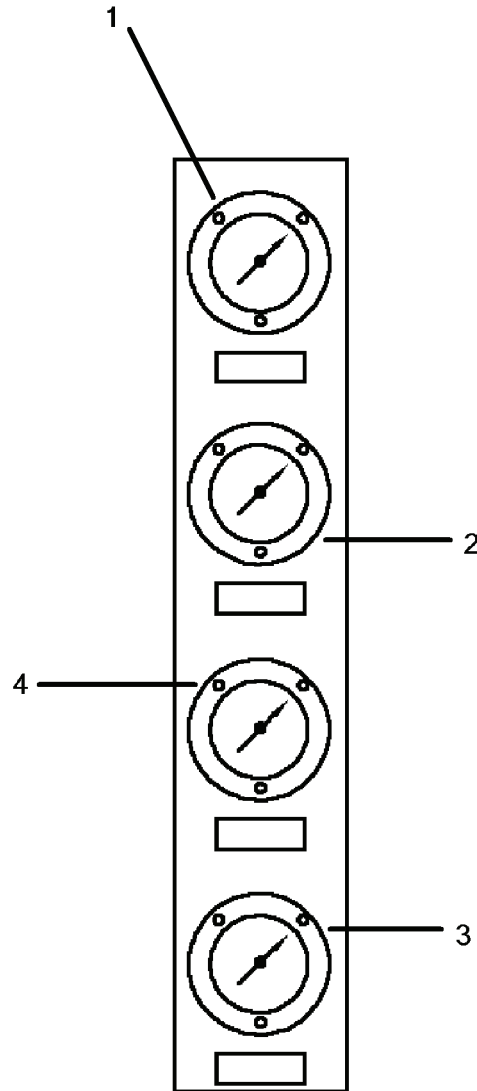

Figure 2-14. Gauge Panel.

2-22. Salinity Power Panel. (Figure 2-15)

This task covers: a. Inspect, b. Test, c. Adjust, d. Repair.

INITIAL SETUP**Tools**

Tool Kit, General Mechanic's,
5180-00-699-5273
Tool Kit, Electrician's,
5180-00391-1087

Equipment Condition

TM 55-1905-223-10, Waste Heat Evaporator and
Salinity Power Panel shutdown and tagged
"Out of Service - Do Not Operate" (FM 55-502).

Materials/Parts

Fuse, 1/4 Amp, P/N 19381
Switch, P/N 14180PC5
Meter, P/N 93001-31
Warning Tag, Item 18, Section II, Appendix C

INSPECT

Inspection of the Salinity Power Panel is accomplished through Preventive Maintenance Checks and Services (PMCS) Table 2-1.

WARNING

Under no circumstances should repair or adjustment of energized equipment be attempted alone. The immediate presence of someone capable of rendering aid is required. Before making adjustments, be sure to protect against grounding. If possible, adjustments should be made with one hand, with the other hand free and clear of equipment. Even when power has been removed from equipment circuits, dangerous potentials may still exist due to retention of charges by capacitors. Circuits must be grounded and all capacitors discharged prior to attempting repairs.

TEST

To test the salinity power panel alarm, proceed as follows:

- a. Open door to salinity power panel (Figure 2-15).
- b. Apply power to the salinity power panel and verify power lamp illuminated.
- c. Depress and hold the toggle switch (7).
- d. Using a philips head screwdriver rotate the set point control screw (8B) until the alarm lamp changes state of illumination.
- e. Verify the desired alarm setting and alarm are the same setting.
- f. Return the set point control screw (8B) to original state of illumination and release toggle switch.

WARNING

Under no circumstances should repair or adjustment of energized equipment be attempted alone. The immediate presence of someone capable of rendering aid is required. Before making adjustments, be sure to protect against grounding. If possible, adjustments should be made with one hand, with the other hand free and clear of equipment. Even when power has been removed from equipment circuits, dangerous potentials may still exist due to retention of charges by capacitors. Circuits must be grounded and all capacitors discharged prior to attempting repairs.

ADJUST

To adjust the salinity power panel alarm set point proceed as follows:

- a. Open door to salinity power panel (Figure 2-15).
- b. Apply power to the salinity control power panel, and verify power lamp illuminated.
- c. Depress and hold the toggle switch (7).
- d. Using a phillips head screwdriver, adjust the alarm set point (8A) to desired setting (0.25 GPG), the alarm light will turn off when meter falls below this setting.
- e. Release the toggle switch.

REMOVAL

WARNING

Always ensure affected circuits have been secured, locked out and tagged out. Performing maintenance with circuits energized may result in death or injury to personnel or equipment damage.

- a. To remove the salinity power switch (13), proceed as follows:
 - (1) Identify and tag all applicable wires and disconnect.
 - (2) Disconnect the fasteners that hold the switch to the panel door, and remove the switch.
- b. To remove the salinity meter (1), proceed as follows:
 - (1) Identify and tag all applicable wires and disconnect.
 - (2) Remove the two nuts from the U-clamp (2) and pull the meter through the front of the panel.
- c. To remove the printed circuit board (PCB) (4), proceed as follows:
 - (1) Identify and tag all applicable wires and disconnect.
 - (2) Remove the four screws and washers, pull out the PCB.
- d. To remove indicator lights (12 or 14), proceed as follows:
 - (1) Identify and tag applicable wiring and disconnect.
 - (2) Remove socket (17 or 16) from door, remove light from socket.
- e. To remove component wiring, proceed as follows:

- (1) Identify and tag applicable wiring.
 - (2) Loosen appropriate conduit locknut (10) and pull conduit elbow down out of power panel.
 - (3) Loosen elbow locknut (15) and pull wiring from elbow and locknut.
- f. To remove the relay (3), gently pull from PCB.
- g. To remove the fuse (9), proceed as follows:
- (1) Remove fuse cover and pull fuse from holder on PCB.
- h. To remove strobe light (6), proceed as follows:
- (1) Unscrew blue strobe lens (5) from top of salinity power panel.
 - (2) Pull strobe light from socket.

REPAIR

Repair of the salinity panel consists of replacing:

- a. Power switch (13).
- b. Salinity meter (1).
- c. Control relay (3).
- d. Printed circuit board (PCB) (4) or fuse (9).

REPLACEMENT

- a. To replace the salinity power switch (13), proceed as follows:
 - (1) Replace switch in panel door and connect the fasteners.
 - (2) Reconnect all applicable wiring.
- b. To replace the salinity meter (1), proceed as follows:
 - (1) Place meter in through the front of the panel door, replace U-clamp (2) onto threaded studs on meter and replace the two nuts.
 - (2) Replace all applicable wiring.
- c. To replace the printed circuit board (PCB) (4), proceed as follows:
 - (1) Replace PCB in power panel with the four screws and washers.
 - (2) Replace all applicable wiring.

- d. To replace indicator lights (12 or 14), proceed as follows:
 - (1) Replace light in socket (17 or 16) and push socket onto door.
 - (2) Reconnect the applicable wiring.
- e. To replace component wiring, proceed as follows:
 - (1) Insert applicable wiring into elbow locknut (15) and elbow, tighten locknut.
 - (2) Insert wiring and elbow into bottom of control panel and place conduit locknut (10) over wiring and tighten onto elbow.
 - (3) Reconnect all wiring.
- f. To replace the relay (3), gently push relay into socket on PCB (4).
- g. To replace the fuse (9), proceed as follows:
 - (1) Push fuse into fuse holder on PCB and replace cover.
- h. To replace strobe light (6), proceed as follows:
 - (1) Push strobe light into socket.
 - (2) Screw blue strobe lens (5) on top of salinity power panel.
- i. Restore electrical power, start the Evaporator, and conduct operational check (Paragraph 2-6.c).
- j. Operate the WHE (Paragraph 2-6.c) and check covers, gaskets, piping and hoses for leaks, correct as necessary.

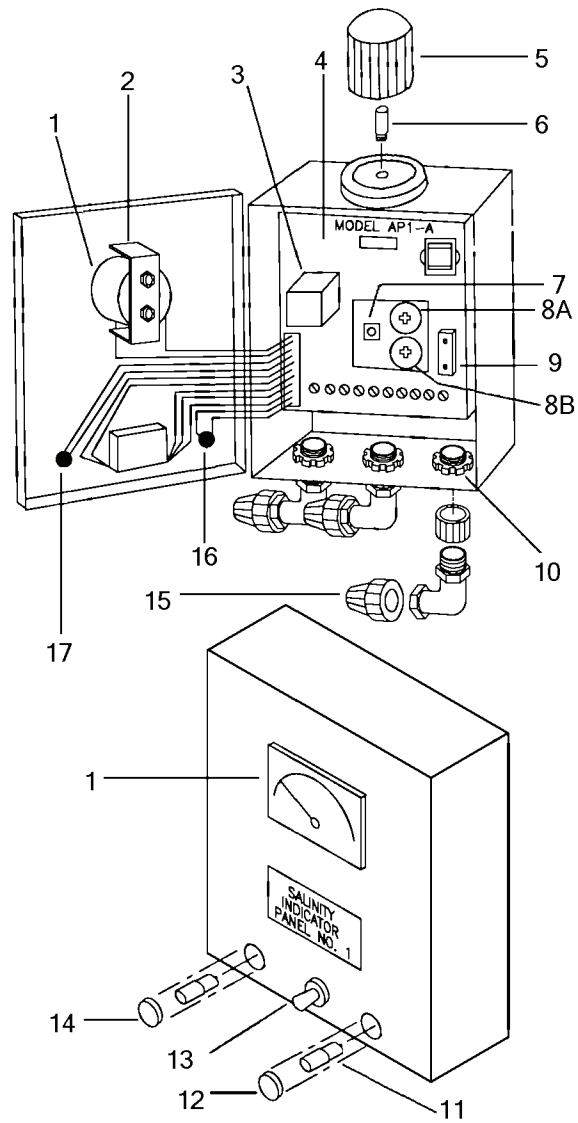

Figure 2-15. Salinity Power Panel.

2-23 Salinity Cell. (Figure 2-16)

This task covers: a. Inspect, b. Test, c. Service, d. Replacement.

INITIAL SETUP

Tools

Tool Kit, General Mechanic's,
5180-00-699-5273
Tool kit, Electrician's,
5180-00391-1087
Dummy Load, Electrical, P/N 2143-1

Equipment Condition

TM 55-1905-223-10, Waste Heat Evaporator
shutdown and tagged "Out of Service - Do Not
Operate" (FM 55-502).

Materials/Parts

Salinity Cell, P/N 9088-37
Alcohol, Item 1, Section II, Appendix C
Teflon Tape, Item 16, Section II, Appendix C
Warning tag, Item 18, Section II, Appendix C
Wiping rags, Item 19, Section II, Appendix C

INSPECT

Inspection of the Salinity Cell is accomplished through Preventive Maintenance Checks and Services (PMCS, TM 55-1905-223-10), Table 2-1.

WARNING

Always ensure affected circuits have been secured, locked out and tagged out. Performing maintenance with circuits energized may result in death or injury to personnel or equipment damage.

TEST

To conduct a salinity cell (Figure 2-16) resistance check, proceed as follows:

NOTE

Apply Teflon Tape to all threaded fittings.

NOTE

Test reading should not be taken before the salinity cell has reached room temperature in not less than 20 minutes after removal from piping system.

- a. Place salinity power panel circuit breaker, at power box P103, in the OFF position.
- b. Secure Evaporator product and brine discharge piping.
- c. Remove salinity cell (1) from product water pipe (2).
- d. Insert test resistor (dummy load) between the two electrodes of the cell.
- e. Apply power to salinity power panel of the cell being tested, from Power panel P103 and the salinity power panel toggle switch.
- f. Meter reading on the salinity power panel should indicate approximately 1 GPG.

- g. Place the salinity power panel toggle switch and circuit breaker (P103) in the OFF position.
- h. Remove test resistor from electrodes.
- i. Reinstall salinity cell back into product water piping.

WARNING

Always ensure affected circuits have been secured, locked out and tagged out. Performing maintenance with circuits energized may result in death or injury to personnel or equipment damage.

REMOVAL

To remove the salinity cell, proceed as follows:

- a. At the salinity control panel identify and tag applicable wires. Disconnect the salinity cell from the power panel.
- b. Shut isolation valve between salinity cell and the distillate pump.
- c. At salinity cell junction box, identify and tag applicable wires. Disconnect the salinity cell from the junction box.
- d. Unscrew the salinity cell (1) from piping (2).
- e. Grasping salinity cell head (1) firmly, pull cell from piping (2).
- f. Inspect electrodes for discoloration, corrosion, and accumulation.

SERVICE

To service the salinity cell proceed as follows:

- a. Clean electrodes with alcohol and a clean cloth to remove any foreign matter.
- b. Wash electrodes with clean distilled water and a clean cloth.
- c. In case of electrodes pitting, or if the cell is unserviceable replace the cell.

NOTE

Apply Teflon Tape to all threaded fittings.

REPLACEMENT

To replace the salinity cell, proceed as follows:

- a. Insert salinity cell (1) into the piping (2) and tighten collar to create seal.
- b. Reconnect salinity cell wires at junction box and salinity power panel.
- c. Align piping, inspect for leaks, and test system for proper operation.
- d. Restore electrical power, start the Evaporator, and conduct operational check (Paragraph 2-6.c).
- e. Operate the WHE (Paragraph 2-6.c) and check covers, gaskets, piping and hoses for leaks, correct as necessary.

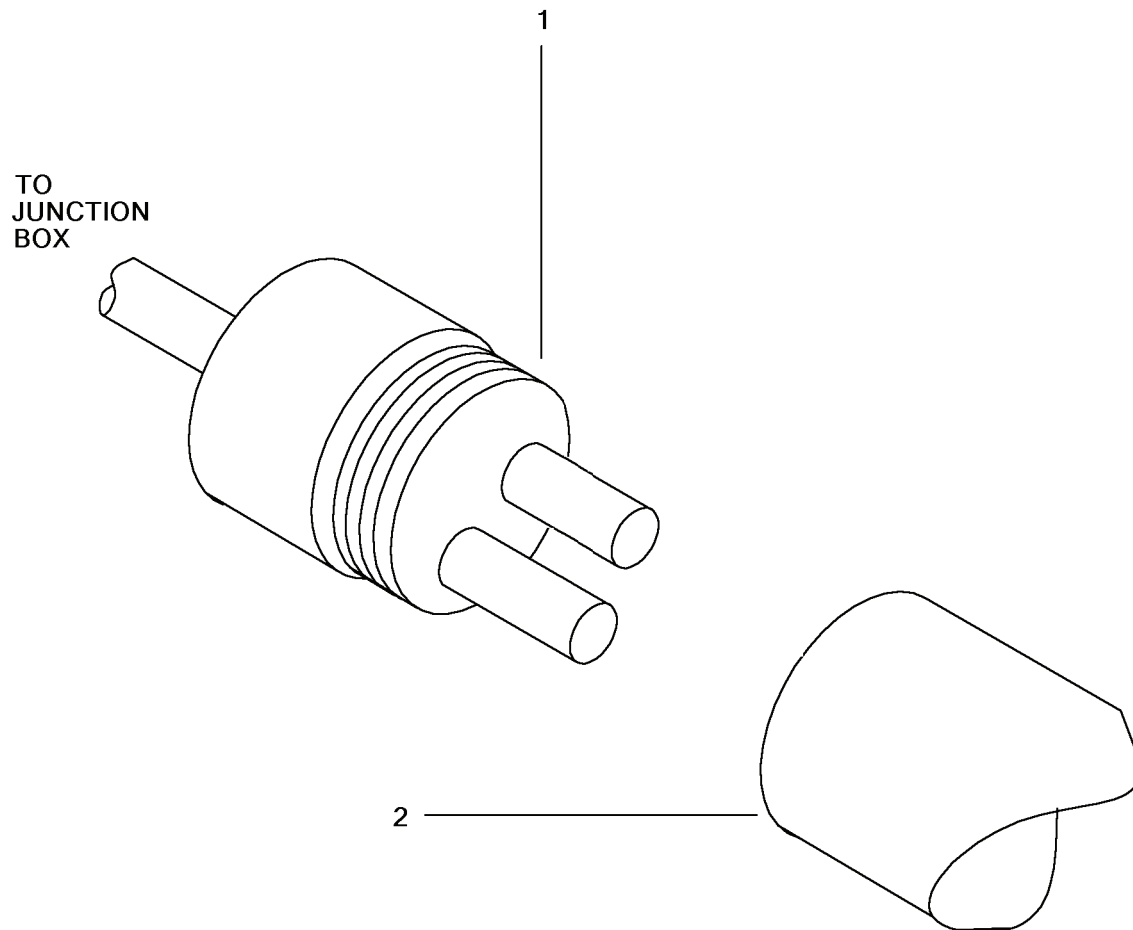

Figure 2-16. Salinity Cell.

2-24. Chemical Feed Treatment Assembly. (Figures 2-17, 2-18 and 2-19)

This task covers: a. Inspect, b. Service, c. Replacement.

INITIAL SETUP

Tools

Tool Kit, General Mechanic's,
5180-00-699-5273

Equipment Condition

TM 55-1905-223-10, Waste Heat Evaporator
shutdown and tagged "Out of Service - Do Not
Operate" (FM 55-502).

Materials/Parts

Ameroyal Feed Treatment, Item 2, Section II,
Appendix C
Gloves, Chemical, Item 6, Section II, Appendix C
Goggles, Item 7, Section II, Appendix C
Respirator, Particulate, Item 13, Section II, Appendix C
Warning Tag, Item 18, Section II, Appendix C
Wiping Rags, Item 19, Section II, Appendix C

INSPECT

- a. Inspect the chemical feed treatment assembly for serviceability, ensure no damage or cracks to tank or lid.
- b. Verify chemical pretreatment level, perform service as required.

WARNING

Always ensure affected circuits have been secured, locked out and tagged out. Performing maintenance with circuits energized may result in death or injury to personnel or equipment damage.

Use protective gloves and safety glasses when working on or around chemical agitator.

SERVICE

To service the chemical feed treatment assembly (Figure 2-17) with AMEROYAL, proceed as follows:

- a. Mix 7 ounces of AMEROYAL in 24 gallons of freshwater in the chemical cleaning tank (4, Figure 2-17).
- b. Adjust the feed rate of the chemical feed injection pump (1) to one gallon per hour (GPH). Pump setting should be approximately at the 70 to 80 percent dial reading.
 - (1) Depress the locking lever (19, Figure 2-18 sheet 2) and rotate output adjust knob (21, Figure 2-18 sheet 2) to desired setting.

WARNING

Always ensure affected circuits have been secured, locked out and tagged out. Performing maintenance with circuits energized may result in death or injury to personnel or equipment damage.

The chemical agitator contains hazardous treatment chemicals that can cause severe burns. Avoid contact with skin. Use protective gloves and safety goggles when working on or around the chemical agitator.

REMOVAL

To remove the chemical feed treatment assembly, proceed as follows:

- a. De-energize the local power switch and unplug the power cord.
- b. Remove chemical feed injection pump suction hose (5, Figure 2-17) from tank lid (3).
- c. Remove the tank top cover (3) from the tank (4).
- d. Remove the chemical agitator assembly (2, Figure 2-17) from the tank top cover (3) by unscrewing the four wing nuts (7, Figure 2-19) from the four bolts (5).
- e. Remove tank (4, Figure 2-17) and tank top cover (3) from chemical feed treatment cabinet.

WARNING

Always ensure affected circuits have been secured, locked out and tagged out. Performing maintenance with circuits energized may result in death or injury to personnel or equipment damage.

The chemical agitator contains hazardous treatment chemicals that can cause severe burns. Avoid contact with skin. Use protective gloves and safety goggles when working on or around the chemical agitator.

REPLACEMENT

To replace the chemical feed treatment assembly, proceed as follows:

- a. Replace the tank (4, Figure 2-17) and tank top cover (3) in the chemical feed treatment cabinet outlet.
- b. Install the chemical agitator assembly on the tank cover and secure with the four wing nuts (7, Figure 2-19) and bolts (5).
- c. Replace tank top cover (3, Figure 2-17) onto tank (4).
- d. Replace chemical feed injection pump suction hose (5).
- e. Plug the power cord in to outlet. Restore electrical power, start the Evaporator, and conduct operational check (Paragraph 2-6.c).
- f. Operate the WHE (Paragraph 2-6.c) and check covers, gaskets, piping and hoses for leaks, correct as necessary.

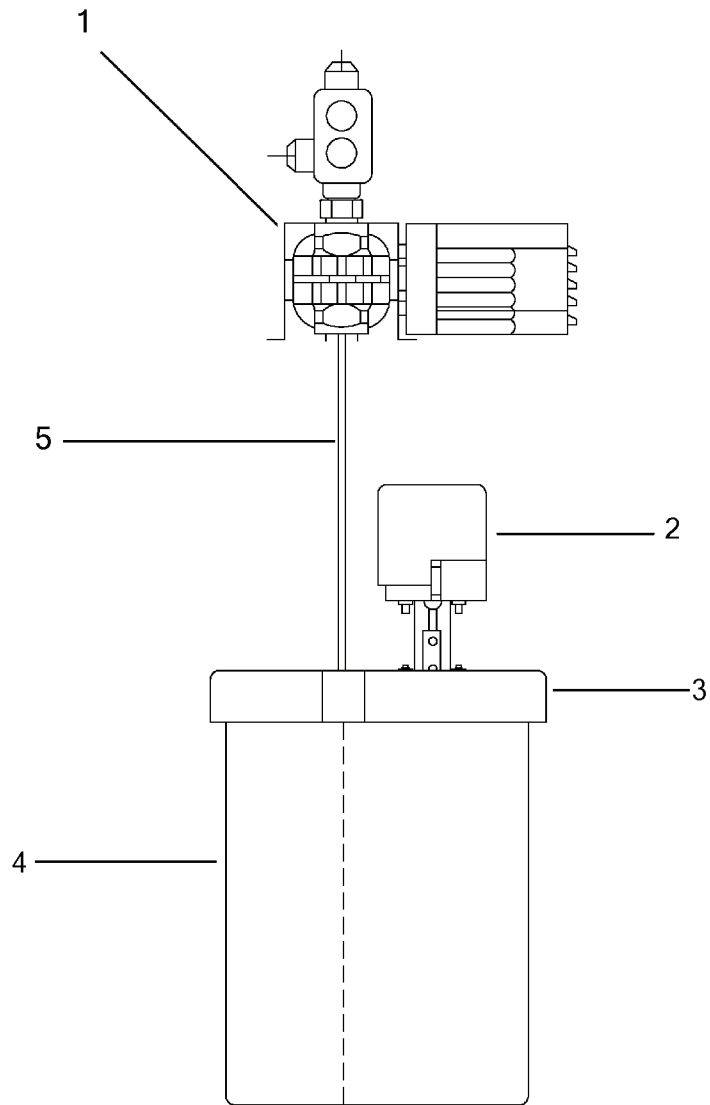

Figure 2-17. Chemical Feed Treatment Assembly.

2-25. Chemical Feed Injection Pump. (Figure 2-18 and 2-12)

This task covers: a. Inspect, b. Adjust, c. Service, d. Repair, e. Replacement.

INITIAL SETUP

Tools

Tool Kit, General Mechanic's,
5180-00-699-5273

Equipment Condition

TM 55-1905-223-10, waste heat Evaporator
shutdown and tagged "Out of Service - Do Not
Operate" (FM 55-502).

Materials/Parts

Gloves, Chemical, Item 6, Section II, Appendix C
Goggles, Item 7, Section II, Appendix C
Muratic Acid 8%, Item 10, Section II, Appendix C
Warning Tag, Item 18, Section II, Appendix C
Wiping Rags, Item 19, Section II, Appendix C

INSPECT

Inspection of the Chemical Feed Injection Pump is accomplished through Preventive Maintenance Checks and Services (PMCS, TM 55-1905-223-10).

NOTE

Feeder must be operating during the adjustment procedure.

ADJUST

To adjust the chemical feed injection pump (Figure 2-18) setting to "zero", proceed as follows:

- a. Remove adjusting knob (21) by removing two set screws.
- b. Remove the dial stop (22), by unscrewing.
- c. Replace adjusting knob (21) and secure with two set screws.
- d. With pump running, loosen the locking lever (19) and turn the adjusting knob (21) counterclockwise until it is "loose" to the touch.
- e. Using light finger pressure, slowly screw the knob in clockwise. Continue to turn until no liquid is coming out of the discharge fitting.
- f. When the light finger pressure is sufficient to hold the movement of the knob steady, tighten the locking lever (19), by turning clockwise. Ensure the knob does not move and there is no liquid coming out of the discharge fitting.
- g. Remove the adjusting knob (21) by removing the two set screws and replace the dial stop (22).
- h. Align adjusting knob (21) pointer to rest on the the dial stop (22) and tighten the set screws.
- i. Loosen the the locking lever (19) to adjust pump setting to correct operating flow; 70-80%.

WARNING

Always ensure affected circuits have been secured, locked out and tagged out. Performing maintenance with circuits energized may result in death or injury to personnel or equipment damage.

The chemical feed injection pump contains hazardous treatment chemicals that can cause severe burns. Avoid contact with skin. Use protective gloves and safety goggles when working on or around the chemical feeder. Use adequate ventilation.

CAUTION

Care should be taken not to drop or lose any of the valve components.

REMOVAL

To remove the chemical feed injection pump assembly (Figure 2-18), proceed as follows:

- a. Secure power at local switch and remove plug (31) from socket.
- b. Remove the four mounting screws from the housing (3) to disconnect from the chemical injection cabinet.
- c. Remove cap screws (12) and washers (14) from head assembly (13), and remove head from housing (3).
- d. Remove the diaphragm (4) from housing (3).
 - (1) Inspect diaphragm for pin holes and tears, replace as necessary.
- e. To remove the five way valve (16), disconnect the hose (17) from the valve and unscrew valve from the discharge valve body (15).
- f. Individually check each ball check (5), valve seat (2), and gasket (6) for cleanliness and serviceability.
- g. To gain access to the ball check (5) in the back check valve assembly (1), hold the injection fitting or valve housing securely and loosen the mating valve housing.
- h. To gain access to the ball check in the foot valve/strainer assembly (7), hold valve housing securely and loosen foot valve seat.
- i. The head assembly (13) valve housings (15 and 7) may be removed by loosening from head.
- j. Remove the Strainer weight (9) from the foot valve strainer assembly after disconnecting the hose (11) from the foot valve (10).
- k. Remove the two screws (33) and the three screws (28) from motor cover (30) and motor cover plate (29).
 - (1) Disconnect the plug (31) wires from the motor to remove the motor cover and motor cover plate.
- l. Remove the bottom housing plate (40).
- m. Remove the three nuts, washers and set screws (18, 37 and 36).
- n. Remove output adjust knob (21) by gently pulling from adjusting screw (20). Slide locking lever (19) off of screw.
- o. After the Motor (27) has been disconnected and adjusting screw (20) has been removed, the drive bracket assembly (26) can be removed:

- (1) Slide the bracket back on the motor shaft to rotate and remove the backing plate (40) and diaphragm return spring (38).
 - (2) When the cam (24) is visible, remove the two set screws (23). Disassemble the motor and bracket from the housing.
- p. Inspect the backing plate (39), with the diaphragm return spring (38), and cam (24) for excessive wear and serviceability.
- (1) The cam should spin freely with minimal drag.

WARNING

Always ensure affected circuits have been secured, locked out and tagged out. Performing maintenance with circuits energized may result in death or injury to personnel or equipment damage.

The chemical feed injection pump contains hazardous treatment chemicals that can cause severe burns. Avoid contact with skin. Use protective gloves and safety goggles when working on or around the chemical feeder. Use adequate ventilation.

CAUTION

Care should be taken not to drop or lose any of the valve parts.

SERVICE

Service to the chemical feed injection pump is applicable to the following components:

- a. To service any of the four ball checks and seats:
 - (1) Identify the ball check to be serviced and perform the appropriate removal procedure.
 - (a) If servicing for troubleshooting purposes, then all ball checks and seats should be serviced.
 - (2) Check seat and ball checks for chips; clean gently. If deformity or deterioration is noted, replace.
 - (3) Perform the appropriate replacement procedure.
- b. To service the chemical injection point (13, Figure 2-12):
 - (1) Disconnect chemical injection point (13) from valve (12) and union fitting (1).
 - (2) Clean injection point parts with 8% Muriatic acid or undiluted vinegar.
 - (3) Reconnect chemical injection point to valve (12) and union fitting (1).

CAUTION

Hand tighten only, do not over tighten. PVC fittings may crack, Using pliers or wrench on fittings can crack pump head.

REPAIR

Repair of the chemical feed injection pump is by replacement of the motor, back check valve assembly, foot valve and replacement of worn or damaged components. Refer to the removal and replacement steps of this procedure.

- a. To repair cracked or torn tubing ends (17 or 11, Figure 2-18, sheet 1 of 2):
 - (1) Disconnect the tubing that is to be repaired.
 - (2) With a knife cut the off the area that has the damage, and reconnect the tubing.
 - (3) If repairing the tubing will not correct the damage, then replacement is required.

WARNING

Always ensure affected circuits have been secured, locked out and tagged out. Performing maintenance with circuits energized may result in death or injury to personnel or equipment damage.

Use protective gloves and safety glasses when working on or around chemical feeder.

CAUTION

Hand tighten only, do not over tighten. PVC fittings may crack, using pliers or wrench on fittings can crack pump head.

REPLACEMENT

To replace the chemical feed injection pump assembly (Figure 2-18), proceed as follows:

- a. Install motor (27) and drive bracket assembly (26) onto housing (3):
 - (1) Connect the cam (24) with the drive bracket assembly (26) on the shaft of the motor with the set screws (23).
 - (2) Install the backing plate (39) and diaphragm return spring (38), slide the bracket back on the motor shaft to rotate into position.
- b. Screw the adjusting screw (20) in to the housing. Replace slide locking lever (19) and knob (21), tighten set screw.
- c. Install the three nuts, washers and set screws (18, 37 and 36) for the motor (27).
- d. Replace the bottom housing plate (40).
- e. Reconnect the plug (31) wires and install the motor cover plate (29) with three screws (28) and the motor cover (30) with 2 screws (33).
- f. Insert each ball check (5), valve seat (2), and gasket (6).
- g. Replace the valve housings (15 and 7) on the head assembly (13).
- h. Screw the five way valve (16) onto the discharge valve body (15) and reconnect the hose (17).
- i. Replace the diaphragm (4) onto the housing (3).
- j. Replace head assembly (13) onto housing (3), secure with washers (14) and capscrews (12).
- k. Install the strainer weight (9) on the hose (11) and attach the foot valve (10).
- l. Connect the back check valve assembly (1) and the hose (17).

- m. Install the housing (3) with four mounting screws on the chemical injection cabinet.
- n. Restore electrical power by inserting plug (31) in socket., and turning local power switch to ON; start the Evaporator, and conduct operational check (Paragraph 2-6.c).
- o. Operate the WHE (Paragraph 2-6.c) and check covers, gaskets, piping and hoses for leaks, correct as necessary.

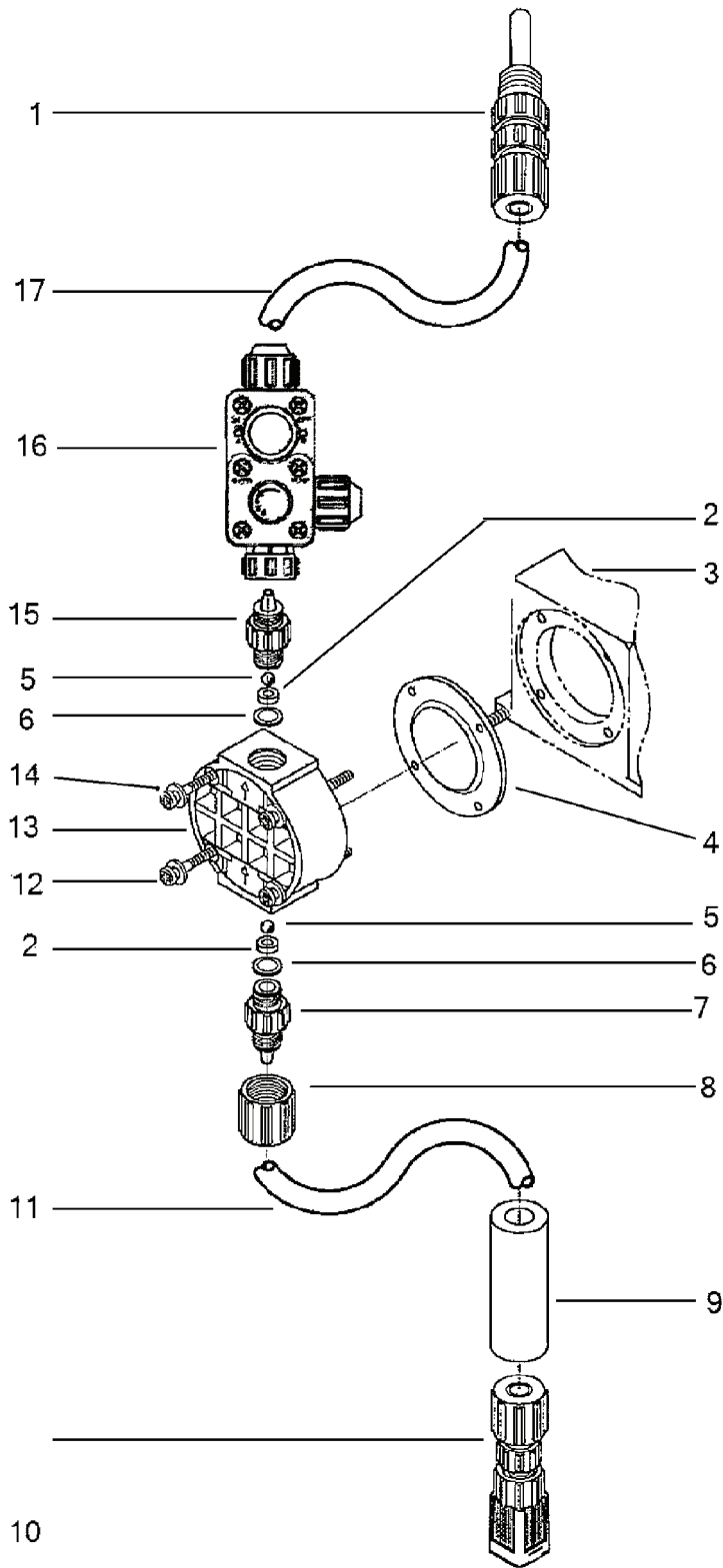

Figure 2-18. Chemical Feed Injection Pump (Sheet 1 of 2).

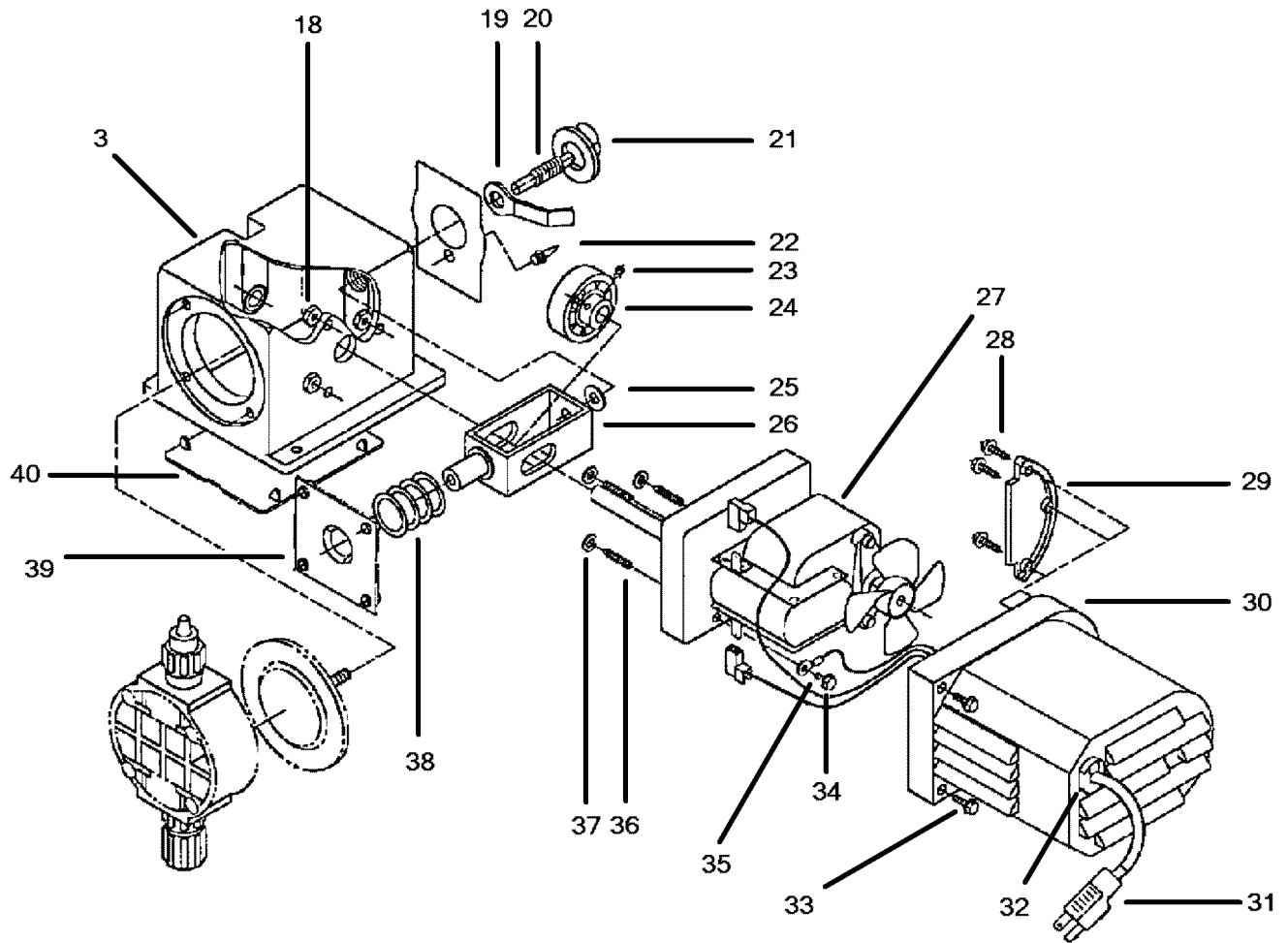

Figure 2-18. Chemical Feed Injection Pump (Sheet 2 of 2).

2-26. Chemical Agitator Assembly. (Figure 2-19)

This task covers: a. Inspect, b. Repair, c. Replacement.

INITIAL SETUP**Tools**

Tool Kit, General Mechanic's,
5180-00-699-5273

Equipment Condition

TM 55-1905-223-10, waste heat Evaporator
shutdown and tagged "Out of Service - Do Not
Operate" (FM 55-502).

Materials/Parts

Gloves, Chemical, Item 6, Section II, Appendix C
Goggles, Item 7, Section II, Appendix C
Warning Tag, Item 18, Section II, Appendix C
Wiping Rags, Item 19, Section II, Appendix C

INSPECT

Inspection of the chemical agitator assembly is accomplished through Preventive Maintenance Checks and Services (PMCS, TM 55-1905-223-10).

WARNING

Always ensure affected circuits have been secured, locked out and tagged out. Performing maintenance with circuits energized may result in death or injury to personnel or equipment damage.

The chemical agitator contains hazardous treatment chemicals that can cause severe burns. Avoid contact with skin. Use protective gloves and safety goggles when working on or around the chemical agitator.

CAUTION

Ensure compliance with Federal and international laws prior to overboard discharge of hazardous materials.

REMOVAL

To remove the chemical agitator assembly (Figure 2-19), proceed as follows:

- a. De-energize the local power switch and unplug the power cord.
- b. Remove the tank top cover from the tank.
- c. Unscrew the four wing nuts (7) from the four bolts (5).
- d. Remove the chemical agitator assembly from the tank top cover.

- e. Disconnect the brackets (4) from the motor (1) by removing the four hex nuts (3) and washers (2).
- f. Disconnect the shaft with impeller (8) from the motor (1) by removing the two set screws (9) from the coupling (10).
- g. Disconnect the electrical cord (11) by opening the electrical cover (12) and disconnecting the wires.

WARNING

Use protective gloves and safety glasses when working on or around jacket water or piping.

REPAIR

Repair of the chemical agitator assembly is by replacement of worn or damaged components.

WARNING

Use protective gloves and safety glasses when working on or around jacket water or piping.

REPLACEMENT

To replace the chemical agitator assembly (Figure 2-19), proceed as follows:

- a. Connect the shaft with impeller (8) to the motor (1) by securing with the two set screws (9) to the coupling (10).
- b. Connect the brackets (4) to the motor (1) with the four hex nuts (3) and washers (2).
- c. Install the chemical agitator assembly on the tank cover and secure with the four wing nuts (7) and bolts (5).
- d. Connect the electrical cord (11) in the motor (1) and replace the electrical cover (12).
- e. Replace tank lid onto tank and plug the electrical cord (11) into outlet.
- f. Restore electrical power, start the Evaporator, and conduct operational check (Paragraph 2-6.c).
- g. Operate the WHE (Paragraph 2-6.c) and check covers, gaskets, piping and hoses for leaks, correct as necessary.

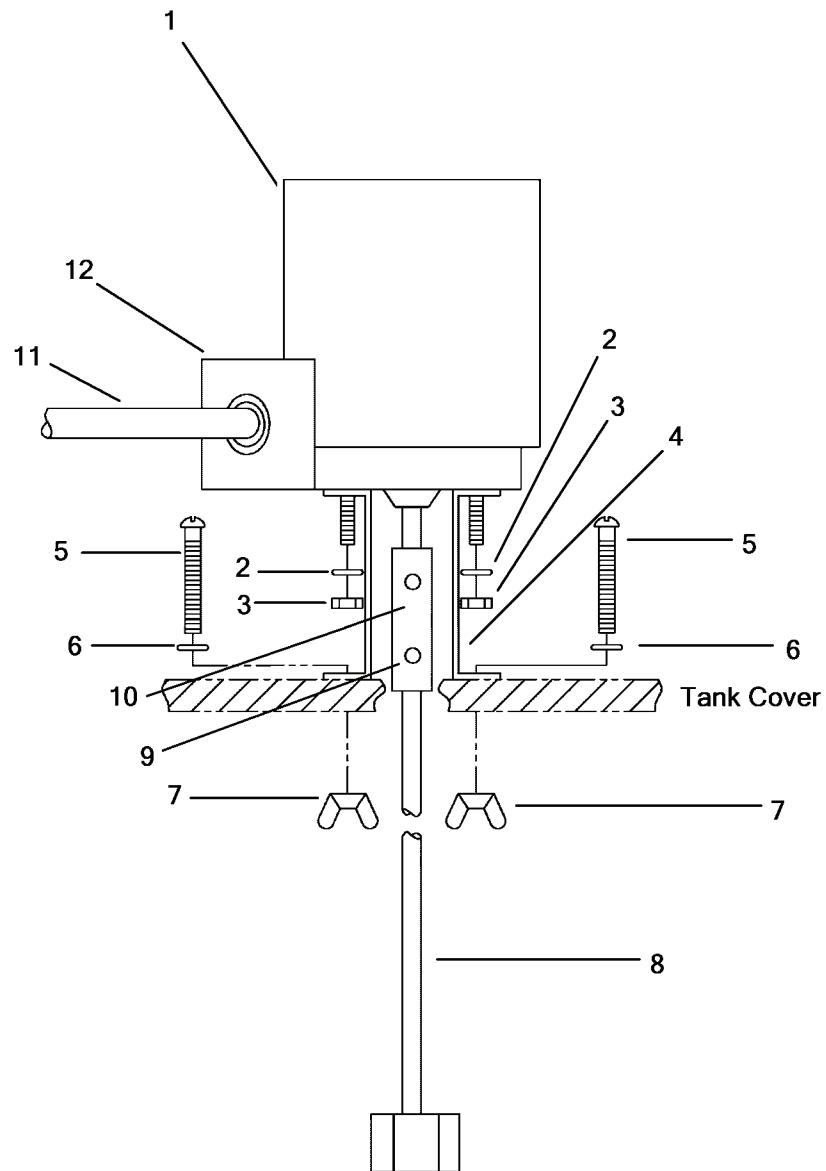

Figure 2-19. Chemical Agitator Assembly.

SECTION VI. PREPARATION FOR STORAGE OR SHIPMENT

2-27. Preparation for Storage or Shipment. In the event of prolonged shutdown of several weeks or winter storage, the following procedure should be observed:

- a. Perform service procedures (Paragraph 2-11) to the Evaporator.
- b. Perform shutdown procedures (Paragraph 2-7.a).
- c. Remove the drain plug from under the Evaporator, and allow the unit to drain.
- d. Disconnect discharge line and distillate hose from distillate pump, allowing the pump housing to drain. After pump is drained reinstall line and hose.
- e. Thoroughly flush Evaporator and lines with a freshwater hose at the drain plug.
- f. Completely drain freshwater from Evaporator and all lines.

CHAPTER 3

INTERMEDIATE DIRECT SUPPORT MAINTENANCE INSTRUCTIONS

	<u>Page</u>
Section I Repair Parts, Special Tools; Test, Measurement and Diagnostic Equipment (TMDE); and Support Equipment	3-1
Section II Service Upon Receipt	3-1
Section III Intermediate Direct Support Preventive Maintenance Checks and Services (PMCS).....	3-2
Section IV Intermediate Direct Support Troubleshooting	3-2
Section V Intermediate Direct Support Maintenance Procedures	3-2
Section VI Preparation for Storage or Shipment	3-6

SECTION I. REPAIR PARTS, SPECIAL TOOLS; TEST, MEASUREMENT, AND DIAGNOSTIC EQUIPMENT (TMDE); AND SUPPORT EQUIPMENT

3-1. Common Tools and Equipment. For authorized common tools and equipment, refer to the Modified Table of Organization and Equipment (MTOE), CTA 50-970, Expendable/Durable Items (Except: Medical, Class V, Repair Parts, and Heraldic Items), CTA 50-909, Field and Garrison Furnishings and Equipment or CTA 8-100, Army Medical Department Expendable/Durable Items, as applicable to your unit.

3-2. Special Tools, TMDE, and Support Equipment. Special tools; test, measurement, and diagnostic equipment; and support equipment requirements are listed and illustrated in the Repair Parts and Special Tools List (RPSTL), TM 55-1905-223-24P. These items are also listed in the Maintenance Allocation Chart (MAC), Appendix B of this manual.

3-3. Repair Parts. Repair parts are listed and illustrated in the Repair Parts and Special Tools List (RPSTL), TM 55-1905-223-24P.

SECTION II. SERVICE UPON RECEIPT

3-4. Checking Unpacked Equipment.

- a. Inspect the equipment for damage incurred during shipment. If the equipment has been damaged, report the damage in accordance with the instructions of DA PAM 750-8.
- b. Check the equipment against the packing slip to see if the shipment is complete. Report all discrepancies in accordance with the instructions of DA PAM 750-8.
- c. Check to see whether the equipment has been modified.
- d. Remove and replace protective caps, plugs, inserts, wrappings, and tape when inspection/inventory is completed. Inspect piping openings for damage. Wipe off dirt, grease, or protective films at time of installation.
- e. Remove chocks from resilient mounted components.

3-5. Initial Setup Procedure. Initial setup includes operational checks and inspections not performed for a routine startup. Intermediate direct support maintenance personnel will accomplish initial setup in accordance with the LCU Operator’s Manual, TM 55-1905-223-10.

3-6. **Normal Startup.** Refer to the LCU Operator's Manual, TM 55-1905-223-10.

3-7. **Shutdown Procedure (Normal Or Emergency).** Refer to the LCU Operator's Manual, TM 55-1905-223-10.

SECTION III. INTERMEDIATE DIRECT SUPPORT PREVENTIVE MAINTENANCE CHECKS AND SERVICES (PMCS)

3-8. **Explanation Of The PMCS Table.** There are no Preventive Maintenance Checks and Services (PMCS) at the Direct Support (DS) level. Refer to Chapter 2, Section III for unit level maintenance procedures.

SECTION IV. INTERMEDIATE DIRECT SUPPORT TROUBLESHOOTING

3-9. **Troubleshooting.** Table 3-1 lists the common fault conditions that may be found during operation or maintenance of the equipment. Look for causes and do corrective actions in the order listed. This manual cannot list every symptom that may show up, and it cannot list all the possible causes and corrective actions. If a symptom is not listed, or if it keeps up after you have performed the corrective actions, notify your supervisor.

Table 3-1. Troubleshooting

Malfunction

Test or Inspection

Corrective Action

1. Unable to maintain adequate Main Engine Jacket Water level.

STEP 1. Seawater heater bundle leaking.

Verify through main engine sight and Evaporator sight glass. (PMCS, TM 55-1905-223-10).

Remove Seawater Heater bundle assembly and inspect (Paragraph 2-17).

Perform Hydrostatic test of bundle (Paragraph 3-11). Replace if necessary.

2. Red alarm indicator and blue strobe illuminated.

STEP 1. Freshwater condenser leak.

Remove freshwater condenser bundle and inspect (Paragraph 2-19).

Perform hydrostatic test if necessary (Paragraph 3-11). Replace if necessary.

SECTION V. INTERMEDIATE DIRECT SUPPORT MAINTENANCE PROCEDURES

3-10. **Maintenance Procedures.** This section provides Direct Support (DS) level maintenance for the Waste Heat Evaporator. The task only covers test and repair.

3-11. Waste Heat Evaporator Model HJ20C. (Figure 3-1)

This task covers: a. Test, b. Repair.

INITIAL SETUP

Tools

Tool Kit, General Mechanic's,
5180-00-699-5272
Tool Kit, Welder's,
5180-00-754-0661
Torch Outfit, Cutting and Welding
Medium Duty, Oxygen and Acetylene,
3433-00-357-8116
Tool Kit, Electrician's,
5180-00391-1087
Strap Wrench, Item 15, Section II, Appendix C
Torque Wrench, Item 17, Section II, Appendix C

Equipment Condition

TM 55-1905-223-10, Waste Heat Evaporator,
Jacket Water Piping Bypassing Pumps,
and Jacket Water Pump Motor Controller
shutdown and tagged "Out of Service-Do Not
Operate" (FM 55-502).

Materials/Parts

Ring Gasket, P/N 95216-31
Rib Gasket, P/N 95217-31
Antiseize Compound, Item 3, Section II, Appendix C
Pail, 5 Gallon, Item 11, Section II, Appendix C
Warning Tag, Item 18, Section II, Appendix C
Wiping Rags, Item 19, Section II, Appendix C

TEST

WARNING

Always ensure affected circuits have been secured, locked out and tagged out. Performing maintenance with circuits energized may result in death or injury to personnel or equipment damage.

NOTE

Performing a hydrostatic test on the seawater heater bundle and the freshwater condenser bundle is conducted in the same manner.

- a. Removal of the seawater heater bundle (Paragraph 2-17) or the freshwater condenser (Paragraph 2-19) must be accomplished prior to performing the test.
- b. With the bundle removed, securely bolt together the bonnet to the bundle with the rib gasket between.
- c. Attach a water hose to one connection on the bonnet and cap off the other.
- d. Apply water to a maximum pressure of 70 PSIG and check for any signs of leaks, holes or damage, repair or replace as necessary.

REMOVAL

- a. To remove the seawater heater bundle (4) perform removal procedures for the jacket water piping group (Paragraph 2-17).
- b. To remove the freshwater bundle (2) perform removal procedures for the feed water piping group (Paragraph 2-19).
- c. To remove remaining piping, perform removal procedures for the distillate piping group (Paragraph 2-12).
- d. Remove hose (3) from distillate pump (5) to distillate trough fitting.
- e. Loosen union fittings at ejector pump (16) and nozzle (17). Remove drain plug from bottom of shell and drain remaining water into the pail.
- f. Remove the nine mounting bolts from Evaporator shell (1) frame to foundation. Rig a suitable lifting device and remove Evaporator shell (1) from foundation.

REPAIR

Repair is limited to the Evaporator shell. In cases where the shell has partially collapsed from low pressure conditions, the shell will need to be checked for sealing capabilities and serviceability. The shell can be returned to an as new condition with some metal and machine work. Direct support will determine the extent of work to be accomplished and repair or replace as needed. Perform hydrostatic test on completion to ensure an air tight seal.

REPLACEMENT

- a. Position Evaporator shell (1) onto foundation. Attach mounting bolts and washers through shell frame to foundation; refer to Appendix D for torque values.
- b. Ensure drain plug is installed in Evaporator shell (1).
- c. To replace the seawater heater bundle (6) perform replacement procedures for the jacket water piping group (Paragraph 2-17).
- d. To replace the freshwater bundle (7) perform replacement procedures for the feed water piping group (Paragraph 2-19).
- e. To replace remaining piping perform replacement procedures for the distillate piping group (Paragraph 2-12).
- f. Replace the hose (3) on to the distillate pump (5) and the distillate trough fitting.
- g. Restore electrical power, start the Evaporator, and conduct operational check (Paragraph 2-6.c).
- h. Operate the WHE (Paragraph 2-6.c) and check covers, gaskets, piping and hoses for leaks, correct as necessary.

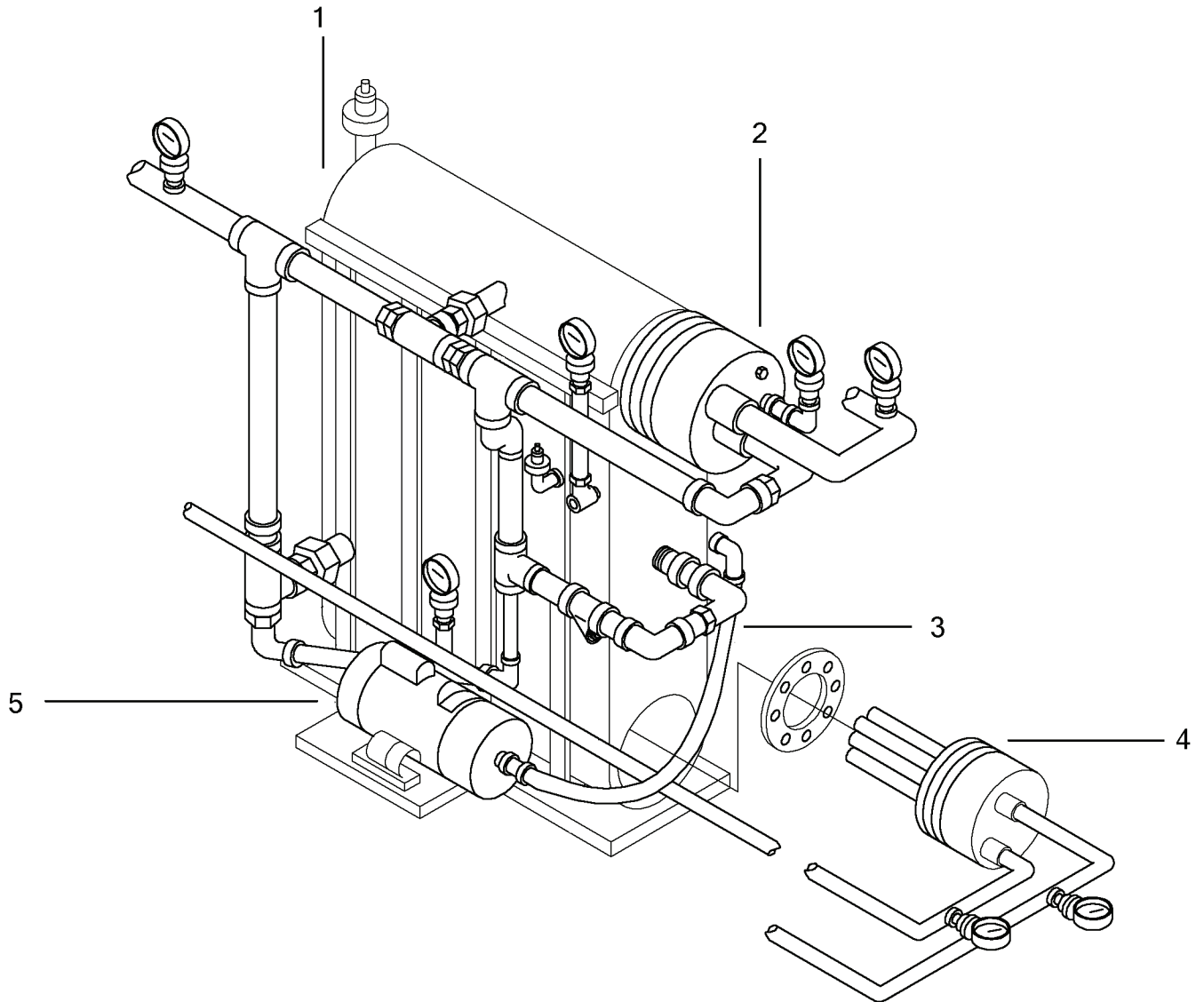

Figure 3-1. Waste Heat Evaporator Model HJ20C.

SECTION VI. PREPARATION FOR STORAGE OR SHIPMENT

3-12. Preparation For Storage Or Shipment. In the event of prolonged shutdown of several weeks or winter storage, the following procedure must be accomplished:

- a. Perform service procedures (Paragraph 2-11) to the Evaporator.
- b. Perform shutdown procedures (Paragraph 2-7.a).
- c. Remove the drain plug from under the Evaporator, and allow the unit to drain.
- d. Disconnect discharge line and distillate hose from distillate pump, allowing the pump housing to drain. After pump is drained reinstall line and hose.
- e. Thoroughly flush Evaporator and lines with a freshwater hose at the drain plug.
- f. Completely drain freshwater from Evaporator and all lines.

CHAPTER 4

INTERMEDIATE GENERAL SUPPORT MAINTENANCE INSTRUCTIONS

Maintenance procedures for the Waste Heat Evaporator are performed at the Unit or Intermediate Direct Support maintenance levels. There are no maintenance requirements at the Intermediate General Support maintenance level.

APPENDIX A

REFERENCES

A-1. Scope. This paragraph lists the manuals, bulletins, specifications, and miscellaneous publications referenced in this manual or required for maintenance activities.

A-2. Field Manuals.

FM 4-25.11	First Aid
FM 31-70	Basic Cold Weather Manual
FM 55-501	Marine Crewman's Handbook
FM 55-502	Army Watercraft Safety

A-3. Technical Manuals.

TM 55-1905-223-10	Operator's Manual for Landing Craft, Utility (LCU)
TM 55-1905-223-24-18-1/2	LCU 2000 Class Basic Craft Maintenance Manual
TM 55-1905-223-24P-1/2/3/4	Repair Parts and Special Tools List for the LCU 2000 Class Watercraft
TM 750-244-3	Destruction of Army Materiel to Prevent Enemy Use
TM 43-0139	Painting Instructions for Army Materiel

A-4. Technical Bulletins.

TB 43-0144	Painting of Watercraft
TB 55-1900-207-24	Treatment of Cooling Water in Marine Diesel Engines
TB 740-97-4	Preservation of Vessels for Storage
TB-55-1900-204-24	Welding on Watercraft

A-5. Military Specifications.

MIL-PRF-16173	Corrosion Preventive Compound, Solvent Cutback, Cold-Application
MIL-PRF-21260	Lubricating Oil, Internal Combustion Engine, Preservative Break-In
MIL-PRF-32033	Lubricating Oil, General Purpose, Preservative (Water-Displacing, Low Temperature)

A-6. Miscellaneous Publications.

DA PAM 750-8	The Army Maintenance Management System (TAMMS) Users Manual
LO 55-1905-223-12	Lubrication Order for the LCU 2000 Class Watercraft
AR 750-10	Army Modification Program

A-7. Forms.

CTA 8-100	Army Medical Department Expendable/Durable Items
CTA 90-970	Army Expendable/Durable Items
DA Form 2028	Recommended Changes to Equipment Technical Publications Blank Forms
DA Form 2404/5988E	Equipment Inspection and Maintenance Worksheet
DA Form 2408-16	Logsheet
DA Form 2410	Logsheet
SF Form 368	Product Quality Deficiency Report

APPENDIX B. MAINTENANCE ALLOCATION CHART (MAC)

SECTION I. INTRODUCTION

B-1 THE ARMY MAINTENANCE SYSTEM MAC.

- a. This introduction (Section I) provides a general explanation of all maintenance and repair functions authorized at various maintenance levels under the standard Army Maintenance System concept.
- b. The Maintenance Allocation Chart (MAC) in Section II designates overall authority and responsibility for the performance of maintenance functions on the identified end item or component. The application of the maintenance functions to the end item or component will be consistent with the capacities and capabilities of the designated maintenance levels, which are shown in the MAC in column (4) as:
 - Unit - includes two subcolumns: C (operator/crew) and O (unit) maintenance.
 - Direct Support - includes an F subcolumn.
 - General Support - includes an H subcolumn.
 - Depot - includes a D subcolumn.
- c. Section III lists the tools and test equipment (both special tools and common tools sets) required for each maintenance function as referenced from Section II.
- d. Section IV contains supplemental instructions and explanatory notes for a particular maintenance function as referenced from Section II.

B-2 MAINTENANCE FUNCTIONS. Maintenance functions will be limited to and defined as follows:

- a. Inspect. To determine the serviceability of an item comparing its physical, mechanical, and/or electrical characteristics with established standards through examination (i.e., by sight, sound, or feel).
- b. Test. To verify serviceability by measuring the mechanical, pneumatic, hydraulic, or electrical characteristics of an item and comparing those characteristics with prescribed standards.
- c. Service. Operations required periodically to keep an item in operating condition, i.e., to clean (includes decontamination, when required), to replace filters, to preserve, to drain, to paint, or to replenish fuel, lubricants, chemical fluids, or gases.
- d. Adjust. To maintain or regulate, within prescribed limits, by bringing into proper or exact position, or by setting the operating characteristics to specified parameters.
- e. Align. To adjust specified variable elements of an item to bring about optimum or desired performance.
- f. Calibrate. To determine and cause corrections to be made or to be adjusted on instruments or test, measuring, and diagnostic equipment used in precision measurement. Consists of comparisons of two instruments, one of which is a certified standard of known accuracy, to detect and adjust any discrepancy in the accuracy of the instrument being compared.
- g. Remove/install. To remove and install the same item when required to perform service or other maintenance functions. Install may be the act of emplacing, seating, or fixing into position a spare, repair part, or module (component or assembly) in a manner to allow the proper functioning of an equipment or system.
- h. Replace. To remove an unserviceable item and install a serviceable counterpart in its place. Replace is authorized by the MAC and is shown as the 3rd position code of the SMR code.
- i. Repair. The application of maintenance services¹ including fault location/troubleshooting², removal/installation, and disassembly/assembly³ procedures, and maintenance actions⁴ to identify troubles and restore serviceability to an item by correcting specific damage, fault, malfunction, or failure in a part, subassembly, module (component or assembly), an item, or system.
- j. Overhaul. That maintenance effort (service/action), prescribed to restore an item to a completely serviceable/operational condition as required by maintenance standards in appropriate technical publications (i.e., DMWR). Overhaul is normally the highest degree of maintenance performed by the Army. Overhaul does not normally return an item to like new condition.

¹Service - Inspect, test, service, adjust, align, calibrate, and/or replace.

²Fault location/troubleshooting - The process of investigating and detecting the cause of equipment malfunctioning; the act of isolating a fault within a system or unit under test (UUT).

³Disassembly/assembly - The step-by-step breakdown (taking apart) of a spare/functional group coded item to the level of its least component, that is assigned an SMR code for the level of maintenance under consideration (i.e., identification as maintenance significant).

⁴Actions - Welding, grinding, riveting, straightening, facing, machining, and/or resurfacing.

- k. Rebuild. Consists of those service/actions necessary for the restoration of unserviceable equipment to a like new condition in accordance with original manufacturing standards. Rebuild is the highest degree of material maintenance applied to Army equipment. The rebuild operation includes the act of returning to zero those age measurements (hours, miles, etc.) considered in classifying Army equipment and components.

B-3 EXPLANATION OF COLUMNS IN THE MAC, SECTION II

- a. Column 1 - Group Number. Column 1 lists functional group code numbers, the purpose of which is to identify maintenance significant components, assemblies, subassemblies, and modules with the next higher assembly.
- b. Column 2 - Component/Assembly. Column 2 contains the names of components, assemblies, subassemblies, and modules for which maintenance is authorized.
- c. Column 3 - Maintenance Function. Column 3 lists the functions to be performed on the item listed in column 2. (For detailed explanation of these functions, see paragraph B-2.)
- d. Column 4 - Maintenance Category. Column 4 specifies, by the listing of a work time figure in the appropriate subcolumn(s), the category of maintenance authorized to perform the function listed in Column 3. This figure represents the active time required to perform that maintenance function at the indicated category of maintenance. If the number or complexity of the tasks within the listed maintenance function varies at different maintenance categories, appropriate work time figures will be shown for each category. The work time figure represents the average time required to restore an item (assembly, subassembly, component, module, end item, or system) to a serviceable condition under typical field operating conditions. This time includes preparation time (including any necessary disassembly/assembly time), troubleshooting/fault location time, and quality assurance/quality control time in addition to the time required to perform the specific tasks identified for the maintenance functions authorized in the maintenance allocation chart. The symbol designations for the various maintenance categories are as follows:
 - C Operator or Crew
 - O Unit Maintenance
 - F Direct Support Maintenance (DS)
 - H General Support Maintenance (GS)
 - D Depot Maintenance
- e. Column 5 - Tools and Equipment. Column 5 specifies, by number code, those common tool sets (not individual tools); special tools; Test, Measurement, and Diagnostic Equipment (TMDE); and support equipment required to perform the designated function, which shall be keyed to the tools listed in Section III.
- f. Column 6 - Remarks. This column shall, when applicable, contain a letter code, in alphabetic order, which shall be keyed to the remarks contained in Section IV.

B-4 EXPLANATION OF COLUMNS IN TOOL AND TEST EQUIPMENT REQUIREMENTS, SECTION III.

- a. Column 1 - Reference Code. The tool and test equipment reference code correlates with a number code used in the MAC, Section II, Column 5.
- b. Column 2 - Maintenance Category. The lowest category of maintenance authorized to use the tool or test equipment.
- c. Column 3 - Nomenclature. Name or identification of the tool or test equipment.
- d. Column 4 - National Stock Number. The National Stock Number (NSN) of the tool or test equipment.
- e. Column 5 - Tool Number. The manufacturer's part number.

B-5 EXPLANATION OF COLUMNS IN REMARKS, SECTION IV.

- a. Column 1- Reference Code. The letter code recorded in Column 6, Section II.
- b. Column 2 - Remarks. This column lists information pertinent to the maintenance function being performed as indicated in the MAC, Section II.

**SECTION II. MAINTENANCE ALLOCATION CHART
FOR
WASTE HEAT EVAPORATOR**

(1) GROUP NUMBER	(2) COMPONENT ASSEMBLY	(3) MAINTENANCE FUNCTION	(4) MAINTENANCE LEVEL					(5) TOOLS AND EQPT	(6) REMARKS
			FIELD			SUSTAINMENT			
			UNIT		DS	GS	DEPOT		
C	O	F	H	D					
07	WASTE HEAT EVAPORATOR MODEL HJ20C	INSPECT TEST SERVICE REPAIR	0.1	0.2	2.0			2	A
0701	DISTILLATE PIPING GROUP	REPAIR		1.5	4.0			2, 3, 4, 5	
070101	DISTILLATE PUMP ASSEMBLY	INSPECT REPLACE REPAIR	0.1	1.5	2.0			2, 5 2, 5	
070102	DISTILLATE DUMP VALVE	INSPECT REPLACE REPAIR	0.1	0.3	1.5			2 2	
070103	ULTRAVIOLET STERILIZER	INSPECT SERVICE REPAIR		0.2	0.5			2	B
070104	PRODUCT WATER FLOW METER	INSPECT REPLACE		0.2	1.0			2	C
0702	JACKET WATER PIPING GROUP	REPAIR		2.0				2, 3, 4	
070201	JACKET WATER PUMP ASSEMBLY	INSPECT REPLACE REPAIR	0.1	1.5	2.0			2, 5 2, 5	
0703	FEED WATER PIPING GROUP	SERVICE REPAIR		1.0	2.0			2, 3, 4	
0704	RELIEF VALVE	REPLACE						2	C
0705	GAUGE PANEL	REPLACE		1.0				2	C

**SECTION II. MAINTENANCE ALLOCATION CHART
FOR
WASTE HEAT EVAPORATOR**

(1) GROUP NUMBER	(2) COMPONENT ASSEMBLY	(3) MAINTENANCE FUNCTION	(4) MAINTENANCE LEVEL					(5) TOOLS AND EQPT	(6) REMARKS
			FIELD		SUSTAINMENT				
			UNIT		DS	GS	DEPOT		
			C	O	F	H	D		
0706	SALINITY POWER PANEL	INSPECT TEST ADJUST REPAIR		0.4 0.5 0.5 1.5				2, 5	
070601	SALINITY CELL	INSPECT TEST SERVICE REPLACE	0.1	0.5 0.2 1.0				1 2 2, 5	C
0707	CHEMICAL FEED TREATMENT ASSEMBLY	INSPECT SERVICE REPLACE		0.1 0.5 .75				2 2	C
070701	CHEMICAL FEED INJECTION PUMP	INSPECT SERVICE ADJUST REPLACE REPAIR	0.1	1.0 0.3 0.5 1.5				2 2 2 2	
070702	CHEMICAL AGITATOR ASSEMBLY	INSPECT REPLACE REPAIR	0.1	0.5 0.5				2 2	B

**SECTION III. TOOLS AND TEST EQUIPMENT REQUIREMENTS
FOR
WASTE HEAT EVAPORATOR**

TOOL OR TEST EQUIPMENT REF CODE	MAINTENANCE CATEGORY	NOMENCLATURE	NATIONAL/NATO STOCK NUMBER	TOOL NUMBER
1	O	Dummy Load, Electrical,	1680-00-775-6086	(81579) P/N 2143-1
2	O	Tool Kit, General Mechanic's,	5180-00-699-5273	(50980) SC-5180-90-CL-N05 (62144)
3	O, F	Tool Kit, Welder's,	5180-00-754-0661	
4	O, F	Torch Outfit, Cutting and Welding Medium Duty, Oxygen and Acetylene,	3433-00-357-8116	
5	O	Tool Kit, Electrician's,	5180-00-391-1087	

**SECTION IV. REMARKS
FOR
WASTE HEAT EVAPORATOR**

REFERENCE CODE	REMARKS
A	Perform service every 150 hours.
B	Change UV Light and filter annually.
C	Repair is by replacement only.

APPENDIX C

EXPENDABLE/DURABLE SUPPLIES AND MATERIALS LIST

SECTION I. INTRODUCTION

- C-1. Scope.** This appendix lists expendable supplies and materials you will need to operate and maintain the equipment. These items are authorized to you by CTA 50-970, Expendable/Durable Items (Except Medical, Class V, Repair Parts, and Heraldic Items), or CTA 8-100 Army Medical Department Expendable/Durable Items.
- C-2. Explanation of Columns.** The following provides an explanation of columns found in the tabular listings.
- a. Column (1) - Item Number. This number is assigned to the entry in the listing and is referenced in the narrative instructions to identify the material (for example, "Use cleaning compound, item 5, App. C").
 - b. Column (2) - Level. This column identifies the lowest level of maintenance that requires the listed item.
 - C - Operator/Crew
 - O - Organizational Maintenance
 - F - Direct Support Maintenance
 - H - General Support Maintenance
 - c. Column (3) National Stock Number. This is the National Stock Number assigned to the item; use it to request or requisition the item.
 - d. Column (4) - Description. Indicates the Federal item name and, if required, a description to identify the item. The last line for each item indicates the Federal Supply Code for Manufacturers (FSCM) in parentheses followed by the part number.
 - e. Column (5) - Unit of Measure (U/M). Indicates the measure used in performing the actual maintenance function. This measure is expressed by a two-character alphabetical abbreviation (for example, ea, in, pr). If the unit of measure differs from the unit of issue, requisition the lowest unit of issue that will satisfy your requirements.

SECTION II. EXPENDABLE/DURABLE SUPPLIES AND MATERIALS LIST

(1) ITEM NUMBER	(2) LEVEL STOCK	(3) NATIONAL STOCK NUMBER	(4) DESCRIPTION	(5) U/M
1	O	6505-01-078-9605	Alcohol	GL
2	O	6850-01-216-5862	Ameroyal Feed Treatment	GL
3	O	8030-00-549-5024	Antiseize Compound (77445) PWA36001	BT
4	O	6810-00-141-2942	Citric Acid	LB
5	O	7930-00-253-0779	Detergent	LB
6	O	8415-01-509-6826	Gloves, Chemical	PR
7	O	4240-01-063-5996	Goggles	EA
8	O	9150-00-257-5358	Grease, Silicone, Insulated Electr (81349) MIL-L-15719	TU
9	O	9150-00-111-3199	Motor Oil	GL
10	O	6810-00-753-4786	Muriatic Acid 8% (Hydrochloric Acid) (58536) A-A-59282	
11	O	7240-01-094-4305	Pail, 5 Gallon	EA
12	O	7240-00-061-1163	Pail, Utility	EA
13	O	4240-01-429-2685	Respirator, Particulate (0FA00) 2200N85	EA
14	O	7920-00-619-9162	Scrub Brush	EA
15	O	5120-01-334-9858	Strap Wrench, Pipe, 1 To 5-Inch (55719)	EA
16	O	3930-01-508-0886	Teflon Tape	RO
17	O	5120-00-776-1841	Torque Wrench	EA
18	O	2835-00-015-0246	Warning Tag	EA
19	O	7920-00-205-3570	Wiping Rags	BL

APPENDIX D

TORQUE VALUES

D-1. **Scope.** SAE capscrews are graded according to the strength of the capscrew. They are marked on the head so the correct strength and torque value are known. The tables in this appendix will list the capscrew markings with correct torque values as well as values for pipe plugs and metric bolts.

CAUTION

When replacing capscrews, always use a capscrew of the same measurement and strength as the capscrew being replaced. Using incorrect capscrews can result in equipment damage. Bolts threaded into aluminum require much less torque.

NOTE

Always use torque values listed in the tables when specific torque values are unknown. The torque values listed in the tables are based on the use of lubricated threads.

Table D-1. Capscrew Markings and Torque Values

Capacity Body size		SAE Grade # 5 Cast Iron or Steel			SAE Grade # 6 or # 7 Cast Iron or Steel			SAE Grade # 8 Cast Iron or Steel		
Inches-Thread		TORQUE			TORQUE			TORQUE		
	Ft-Lb	kgm	Nm	Ft-Lb	kgm	Nm	Ft-lb	kgm	Nm	
1/4	-29	8	1.1064	10.8465	10	1.3630	13.5582	12	1.6596	16.2698
	-28	10	1.3830	13.5582				14	1.9362	18.9815
5/16	-18	17	2.3511	23.0489	19	2.6277	25.7605	24	3.3192	32.5396
	-24	19	2.6277	25.7605				27	3.7341	36.6071
3/8	-16	31	4.2873	42.0304	34	4.7022	46.0978	44	6.0852	59.6560
	-24	35	4.8405	47.4536				49	6.7767	66.4351
7/16	-14	49	6.7767	66.4351	55	7.6065	74.5700	70	9.6810	94.9073
	-20	55	7.6065	74.5700				78	10.7874	105.753
1/2	-13	75	10.3725	101.6863	85	11.7555	115.2445	105	14.5215	142.3609
	-20	85	11.7555	115.2445				120	16.5860	162.6960
9/16	-12	110	15.2130	149.1380	120	16.5960	162.6960	155	21.4365	210.1490
	-18	120	16.5960	162.6960				170	23.5110	230.4860
5/8	-11	150	20.7450	203.3700	167	23.0961	226.4186	210	29.0430	284.7180
	-18	170	23.5110	230.4860				240	33.1920	325.3920
3/4	-10	270	37.3410	366.0660	280	38.7240	379.6240	375	51.8625	508.4250
	-16	295	40.7985	399.9610				420	58.0860	568.4360
7/8	-9	395	54.6285	535.5410	440	60.8520	596.5520	605	83.6715	820.2590
	-14	435	60.1605	589.7730				675	93.3525	915.1650
1.0	-8	590	81.5970	799.9220	660	91.2780	894.8280	910	125.8530	1233.7780
	-14	660	91.2780	849.8280				990	136.9170	1342.2420

Capscrew Head Markings

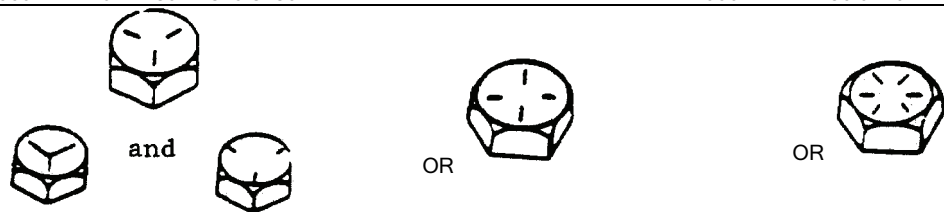

Table D-2. Pipe Plug Torque Values

Thread	Size		In Aluminum Components Torque		In Cast Iron or Steel Components Torque	
	Actual	Thread O.D				
in	Nm	(in)	Nm	(ft-lbs)	Nm	(ft-lbs)
1/16	8.1	(0.32)	5	(45 in-lbs)	15	(10)
1/8	10.4	(0.41)	15	(10)	20	(15)
1/4	13.7	(0.54)	20	(15)	25	(20)
3/8	17.3	(0.68)	25	(20)	35	(25)
1/2	21.6	(0.85)	35	(25)	55	(40)
3/4	26.7	(1.05)	45	(35)	75	(55)
1	33.5	(1.32)	60	(45)	95	(70)
1-1/4	42.2	(1.66)	75	(55)	115	(85)
1-1/2	48.3	(1.90)	85	(65)	135	(100)

Table D-3. Metric Bolt Torque Values

Thread for general purposes (size x pitch (mm))	Cast Iron or Steel			
	Head Mark 4 Torque		Head Mark 7 Torque	
	ft-lb.	(Nm)	ft-lb.	(Nm)
6 x 1.0	2.2 to 2.9	(3.0 to 3.9)	3.6 to 5.8	(4.9 to 7.8)
8 x 1.25	5.8 to 8.7	(7.9 to 12)	9.4 to 14	(13 to 19)
10 x 1.25	12 to 17	(16 to 23)	20 to 29	(27 to 39)
12 x 1.25	21 to 32	(29 to 43)	35 to 53	(47 to 72)
14 x 1.5	35 to 52	(48 to 70)	57 to 85	(77 to 110)
16 x 1.5	51 to 77	(67 to 100)	90 to 120	(130 to 160)
18 x 1.5	74 to 110	(100 to 150)	130 to 170	(180 to 230)
20 x 1.5	110 to 140	(150 to 190)	190 to 240	(160 to 320)
22 x 1.5	150 to 190	(200 to 260)	250 to 320	(340 to 430)
24 x 1.5	190 to 240	(260 to 320)	310 to 410	(420 to 550)

GLOSSARY

ABBREVIATIONS AND DEFINITIONS

<u>ABBREVIATION</u>	<u>DEFINITION</u>
AR	As Required
ASW	Auxiliary Seawater
BHP	Brake Horsepower
BT	Bottle
BTU/LB	British Thermal Units Per Pound
BX	Box
°C	Degrees Celsius
CAGE	Commercial and Government Entity code
cm	Centimeter
D	Daily
DIST	Distribution
DMWR	Depot Maintenance Work Requirements
ea	Each
EIR	Equipment Improvement Recommendations
EOS	Enclosed Operating Station
EVAP	Evaporator
°F	Degrees Fahrenheit
ft-lb	Foot Pound
FW	Freshwater
GPD	Gallons Per Day
GPG	Grain Per Gallon
GPH	Gallons Per Hour
GPM	Gallons Per Minute
H	Height
HJW	Hot Jacket Water
HP	Horsepower
H. P.	High Pressure
hrs	Hours
Hz	Hertz
I. D.	Inside Diameter
inHg	Inches of Mercury
JW	Jacket Water
JWBP	Jacket Water Booster Pump
kg	Kilogram
kPa	Kilo Pascal
L	Length
lb	Pound
LCU	Landing Craft Utility
M	Monthly
MAC	Maintenance Allocation Chart
MCHRY	Machinery
MTOE	Modified Table of Organization and Equipment
N*m or N-m	Newton Meters
NATO	North Atlantic Treaty Organization
NICP	National Inventory Control Point
no.	Number
NSN	National Stock Number
oz	Ounce
P/N	Part Number
para	Paragraph
PMCS	Preventive Maintenance Checks and Services
ppm	Parts Per Million

ABBREVIATION

psi
psig
Q
qty
RD
RO
RPM
RPSTL
S
SAE
SMR
SW
TDS
TM
TMDE
U/M
UV
Vdc
VAC
W

DEFINITION

Pounds Per Square Inch
Pounds Per Square Inch Gauge
Quarterly
Quantity
Round
Roll
Revolutions Per Minute
Repair Parts and Special Tools List
Semiannually
Society of American Engineers
Supply Maintenance Recoverability
Seawater
Total Dissolved Solids
Technical Manual
Test, Measurement, and Diagnostic Equipment
Unit of Measure
Ultraviolet
Volts Direct Current
Volts Alternating Current
Weekly/Width

ALPHABETICAL INDEX

Subject, Paragraph	Subject, Paragraph
C	G
Characteristics, Capabilities And Features, 1-6	Gauge Panel, 2-21
Checking Unpacked Equipment, 2-4, 3-4	Removal, 2-21
Chemical Agitator Assembly, 2-26	Replacment, 2-21
Inspect, 2-26	I
Remove, 2-26	Initial Setup Procedures, 3-5
Repair, 2-26	J
Replacement, 2-26	Jacket Water Piping Group, 2-17
Chemical Feed Injection Pump, 2-25	Removal, 2-17
Adjust, 2-25	Repair, 2-17
Inspect, 2-25	Replacement, 2-17
Removal, 2-25	Jacket Water Pump Assembly, 2-18
Repair, 2-25	Inspect, 2-18
Replacement, 2-25	Removal, 2-18
Service, 2-25	Repair, 2-18
Chemical Feed Treatment Assembly, 2-24	Replacement, 2-18
Inspect, 2-24	L
Removal, 2-24	Location And Description Of Major Components, 1-7
Replacement, 2-24	M
Service. 2-24	Maintenance Forms , Records And Reports, 1-2
Common Tools And Equipment, 2-1, 3-1	Maintenance Of Waste Heat Evaporator, 2-10
D	Maintenance Procedures, 3-10
Deprocessing Unpacked Equipment, 2-5	N
Destruction Of Army Materiel, 1-3	Normal Startup, 3-6
Distillate Dump Valve, 2-14	P
Inspect, 2-14	Preliminary Servicing And Adjustment, 2-6
Removal, 2-14	Preparation For Storage Or Shipment, 1-5, 2-27, 3-12
Repair, 2-14	Principles Of Operation, 1-10
Replacement, 2-14	Product Water Flow Meter, 2-16
Distillate Piping Group, 2-12	Inspect, 2-16
Removal, 2-12	Removal, 2-16
Repair, 2-12	Replacement, 2-16
Replacement, 2-12	R
Distillate Pump Assembly, 2-13	Relief Valve, 2-20
Inspect, 2-13	Removal, 2-20
Removal, 2-13	Replacement, 2-20
Repair, 2-13	
Replacement, 2-13	
E	
Equipment Data, 1-8	
Explanantion Of PMCS Table, 2-8, 3-8	
F	
Feed Water Piping Group, 2-19	
Removal, 2-19	
Repair, 2-19	
Replacement, 2-19	
Service, 2-19	

Subject, Paragraph

R

Repair Parts, 2-3, 3-3
 Reporting Equipment Improvement
 Recommendations, 1-4

S

Safety, Care And Handling, 1-9
 Salinity Cell, 2-23
 Inspect, 2-23
 Removal, 2-23
 Repair, 2-23
 Replacment, 2-23
 Service, 2-23
 Test, 2-23
 Salinity Power Panel, 2-22
 Adjust, 2-22
 Inspect, 2-22
 Removal, 2-22
 Repair, 2-22
 Replacement, 2-22
 Test, 2-22
 Scope Of Manual, 1-1
 Shutdown Procedure, 2-7, 3-7
 Special Tools, TMDE And Support
 Equipment, 2-2, 3-2

Subject, Paragraph

S

System Component Location
 And Description, 1-7.2
 System Water Locations And
 Definitions, 1-7.1

T

Troubleshooting, 2-9, 3-9

U

Ultraviolet Sterilizer, 2-15
 Inspect, 2-15
 Removal, 2-15
 Repair, 2-15
 Replacement, 2-15
 Service, 2-15

W

Waste Heat Evaporator Model HJ20C, 2-11, 3-11
 Inspect, 2-11
 Removal, 3-11
 Repair, 3-11
 Replacement, 3-11
 Service, 2-11
 Test, 2-11, 3-11

These are the instructions for sending an electronic 2028.

The following format must be used if submitting an electronic 2028. The subject line must be exactly the same and all fields must be included; however, only the following fields are mandatory: 1, 3, 4, 5, 6, 7, 8, 9, 10, 13, 15, 16, 17 and 27.

From: "Whomever" whomever@avma27.army.mil
To: whomever@avma27.army.mil
To: TACOM-TECH-PUBS@ria.army.mil

Subject: DA Form 2028

1. **From:** Joe Smith
2. **Unit:** home
3. **Address:** 4300 Park
4. **City:** Hometown
5. **St:** MO
6. **Zip:** 77777
7. **Date Sent:** 19-OCT-93
8. **Pub no:** 55-1915-200-10
9. **Pub Title:** TM
10. **Publication Date:** 11-APR-88
11. **Change Number:** 12
12. **Submitter Rank:** MSG
13. **Submitter Fname:** Joe
14. **Submitter Mname:** T
15. **Submitter Lname:** Smith
16. **Submitter Phone:** 123-123-1234
17. **Problem:** 1
18. **Page:** 1
19. **Paragraph:** 3
20. **Line:** 4
21. **NSN:** 5
22. **Reference:** 6
23. **Figure:** 7
24. **Table:** 8
25. **Item:** 9
26. **Total:** 123
27. **Text:**

This is the text for the problem below line 27.

RECOMMENDED CHANGES TO PUBLICATIONS AND BLANK FORMS For use of this form, see AR 310-1; the proponent agency is the US Army Adjutant General Center.						Use Part II (reverse) for Repair Parts and Special Tool Lists (RPSTL) and Supply Catalogs/Supply Manuals (SC/SM).	DATE: Date form is filled out.
TO: (Forward to proponent of publication or form) (Include ZIP Code) Mailing address found on title block page.						FROM: (Activity and location) (Include ZIP Code) Your mailing address.	
PART I - ALL PUBLICATIONS (EXCEPT RPSTL AND SC/SM) AND BLANK FORMS							
PUBLICATION/FORM NUMBER: TM X-XXXX-XXX-XXX						DATE: Date of the TM.	TITLE: Title of TM.
ITEM NO.	PAGE NO.	PARA-GRAPH	LINE NO.	FIGURE NO.	TABLE NO.	RECOMMENDED CHANGES AND REASON (Exact wording of recommended change must be given)	
	0019 00 1	3	1	1		Step No. 2 says to secure doors open with locking bar or hooks from where to what? The bars or hooks are not identified.	
	0019 00 4	4	1	1		Step No. 19 states to remove locking bars, pins or hooks from where to what? The bars, pins or hooks are not identified. Where are they stored?	
SAMPLE							
* Reference to line numbers within the paragraph or subparagraph.							
TYPED NAME, GRADE OR TITLE Doe, John, CPL				TELEPHONE EXCHANGE/AUTOVON, PLUS EXTENSION 755-1313		SIGNATURE CPL John Doe	

TO: (Forward to proponent of publication or form) (Include ZIP Code)	FROM: (Activity and location) (Include ZIP Code)	DATE:
---	---	--------------

PART II - REPAIR PARTS AND SPECIAL TOOL LISTS AND SUPPLY CATALOGS/SUPPLY MANUALS

PUBLICATION/FORM NUMBER: TM X-XXXX-XXX-XXX	DATE: Date of the TM.	TITLE: Title of TM.
--	---------------------------------	-------------------------------

PAGE NO.	COLM NO.	LINE NO.	FEDERAL STOCK NUMBER	REFERENCE NO.	FIGURE NO.	ITEM NO.	TOTAL NO. OF MAJOR ITEMS SUPPORTED	RECOMMENDED ACTION

SAMPLE

PART III - REMARKS (Any general remarks or recommendations, or suggestions for improvement of publications and blank forms. Additional blank sheets may be used if more space is needed.)

* Reference to line numbers within the paragraph or subparagraph.

TYPED NAME, GRADE OR TITLE Doe, John, CPL	TELEPHONE EXCHANGE/AUTOVON, PLUS EXTENSION 755-1313	SIGNATURE <i>CPL John Doe</i>
--	--	--------------------------------------

RECOMMENDED CHANGES TO PUBLICATIONS AND BLANK FORMS For use of this form, see AR 25-30; the proponent agency is OAASA	Use Part II (<i>reverse</i>) for Repair Parts and Special Tool Lists (RPSTL) and Supply Catalogs/Supply Manuals (SC/SM).	DATE
---	--	-------------

TO (<i>Forward to proponent of publication or form</i>) (<i>Include ZIP Code</i>) AMSTA-LC-LMPP / TECH PUBS, TACOM-RI 1 Rock Island Arsenal, Rock Island, IL 61299-7630	FROM (<i>Activity and location</i>) (<i>Include ZIP Code</i>)
---	--

PART I - ALL PUBLICATIONS (EXCEPT RPSTL AND SC/SM) AND BLANK FORMS

PUBLICATION/FORM NUMBER TM 55-1905-223-24-7	DATE 08 Feb 08	TITLE WASTE HEAT EVAPORATOR FOR LANDING CRAFT UTILITY NSN 1905-01-154-1191
---	--------------------------	--

ITEM	PAGE	PARA-GRAPH	LINE	FIGURE NO.	TABLE	RECOMMENDED CHANGES AND REASON

** Reference to line numbers within the paragraph or subparagraph.*

TYPED NAME, GRADE OR TITLE	TELEPHONE EXCHANGE/AUTOVON, PLUS EXTENSION	SIGNATURE
-----------------------------------	---	------------------

TO <i>(Forward direct to addressee listed in publication)</i> AMSTA-LC-LMPP / TECH PUBS, TACOM-RI 1 Rock Island Arsenal Rock Island, IL 61299-7630	FROM <i>(Activity and location) (Include ZIP Code)</i>	DATE
--	---	-------------

PART II - REPAIR PARTS AND SPECIAL TOOL LISTS AND SUPPLY CATALOGS/SUPPLY MANUALS

PUBLICATION NUMBER TM 55-1905-223-24-7	DATE 08 Feb 08	TITLE WASTE HEAT EVAPORATOR FOR LANDING CRAFT UTILITY NSN 1905-01-154-1191
--	--------------------------	---

PAGE NO.	COLM NO.	LINE NO.	NATIONAL STOCK NUMBER	REFERENCE NO.	FIGURE NO.	ITEM NO.	TOTAL NO. OF MAJOR ITEMS SUPPORTED	RECOMMENDED ACTION

PART III - REMARKS *(Any general remarks, recommendations, or suggestions for improvement of publications and blank forms. Additional blank sheets may be used if more space is needed.)*

TYPED NAME, GRADE OR TITLE	TELEPHONE EXCHANGE/AUTOVON, PLUS EXTENSION	SIGNATURE
-----------------------------------	---	------------------

RECOMMENDED CHANGES TO PUBLICATIONS AND BLANK FORMS						Use Part II (<i>reverse</i>) for Repair Parts and Special Tool Lists (RPSTL) and Supply Catalogs/Supply Manuals (SC/SM).	DATE
For use of this form, see AR 25-30; the proponent agency is OAASA							
TO (<i>Forward to proponent of publication or form</i>) (<i>Include ZIP Code</i>) AMSTA-LC-LMPP/TECH PUBS, TACOM-RI, 1 Rock Island Arsenal, Rock Island, IL 61299-7630						FROM (<i>Activity and location</i>) (<i>Include ZIP Code</i>)	
PART I - ALL PUBLICATIONS (EXCEPT RPSTL AND SC/SM) AND BLANK FORMS							
PUBLICATION/FORM NUMBER TM 55-1905-223-24-7						DATE 08 Feb 08	TITLE WASTE HEAT EVAPORATOR FOR LANDING CRAFT UTILITY NSN 1905-01-154-1191
ITEM	PAGE	PARA- GRAPH	LINE	FIGURE NO.	TABLE	RECOMMENDED CHANGES AND REASON	
<i>* Reference to line numbers within the paragraph or subparagraph.</i>							
TYPED NAME, GRADE OR TITLE						TELEPHONE EXCHANGE/AUTOVON, PLUS EXTENSION	SIGNATURE

TO <i>(Forward direct to addressee listed in publication)</i> AMSTA-LC-LMPP/TECH PUBS, TACOM-RI 1 Rock Island Arsenal Rock Island, IL 61299-7630	FROM <i>(Activity and location) (Include ZIP Code)</i>	DATE
--	---	-------------

PART II - REPAIR PARTS AND SPECIAL TOOL LISTS AND SUPPLY CATALOGS/SUPPLY MANUALS

PUBLICATION NUMBER TM 55-1905-223-24-7	DATE 08 Feb 08	TITLE WASTE HEAT EVAPORATOR FOR LANDING CRAFT UTILITY NSN 1905-01-154-1191
--	--------------------------	---

PAGE NO.	COLM NO.	LINE NO.	NATIONAL STOCK NUMBER	REFERENCE NO.	FIGURE NO.	ITEM NO.	TOTAL NO. OF MAJOR ITEMS SUPPORTED	RECOMMENDED ACTION

PART III - REMARKS *(Any general remarks, recommendations, or suggestions for improvement of publications and blank forms. Additional blank sheets may be used if more space is needed.)*

TYPED NAME, GRADE OR TITLE	TELEPHONE EXCHANGE/AUTOVON, PLUS EXTENSION	SIGNATURE
-----------------------------------	---	------------------

RECOMMENDED CHANGES TO PUBLICATIONS AND BLANK FORMS For use of this form, see AR 25-30; the proponent agency is OAASA	Use Part II (<i>reverse</i>) for Repair Parts and Special Tool Lists (RPSTL) and Supply Catalogs/Supply Manuals (SC/SM).	DATE
---	--	-------------

TO (<i>Forward to proponent of publication or form</i>) (<i>Include ZIP Code</i>) AMSTA-LC-LMPP/TECH PUBS, TACOM-RI 1 Rock Island Arsenal, Rock Island, IL 61299-7630	FROM (<i>Activity and location</i>) (<i>Include ZIP Code</i>)
--	--

PART I - ALL PUBLICATIONS (EXCEPT RPSTL AND SC/SM) AND BLANK FORMS

PUBLICATION/FORM NUMBER TM 55-1905-223-24-7	DATE 08 Feb 08	TITLE WASTE HEAT EVAPORATOR FOR LANDING CRAFT UTILITY NSN 1905-01-154-1191
---	--------------------------	--

ITEM	PAGE	PARA-GRAPH	LINE	FIGURE NO.	TABLE	RECOMMENDED CHANGES AND REASON

* Reference to line numbers within the paragraph or subparagraph.

TYPED NAME, GRADE OR TITLE	TELEPHONE EXCHANGE/AUTOVON, PLUS EXTENSION	SIGNATURE
-----------------------------------	---	------------------

TO <i>(Forward direct to addressee listed in publication)</i> AMSTA-LC-LMPP/TECH PUBS, TACOM-RI 1 Rock Island Arsenal Rock Island, IL 61299-7630	FROM <i>(Activity and location) (Include ZIP Code)</i>	DATE
--	---	-------------

PART II - REPAIR PARTS AND SPECIAL TOOL LISTS AND SUPPLY CATALOGS/SUPPLY MANUALS

PUBLICATION NUMBER TM 55-1905-223-24-7	DATE 08 Feb 08	TITLE WASTE HEAT EVAPORATOR FOR LANDING CRAFT UTILITY NSN 1905-01-154-1191
--	--------------------------	---

PAGE NO.	COLM NO.	LINE NO.	NATIONAL STOCK NUMBER	REFERENCE NO.	FIGURE NO.	ITEM NO.	TOTAL NO. OF MAJOR ITEMS SUPPORTED	RECOMMENDED ACTION

PART III - REMARKS *(Any general remarks, recommendations, or suggestions for improvement of publications and blank forms. Additional blank sheets may be used if more space is needed.)*

TYPED NAME, GRADE OR TITLE	TELEPHONE EXCHANGE/AUTOVON, PLUS EXTENSION	SIGNATURE
-----------------------------------	---	------------------

By Order of the Secretary of the Army:

Official:



JOYCE E. MORROW
*Administrative Assistant to the
Secretary of the Army*
0801607

GEORGE W. CASEY, JR.
*General, United States Army
Chief of Staff*

DISTRIBUTION: To be distributed in accordance with the Initial Distribution Number (IDN) 254805, requirements for TM 55-1905-223-24-7.

The Metric System and Equivalents

Linear Measure

1 centimeter = 10 millimeters = .39 inch
 1 decimeter = 10 centimeters = 3.94 inches
 1 meter = 10 decimeters = 39.37 inches
 1 dekameter = 10 meters = 32.8 feet
 1 hectometer = 10 dekameters = 328.08 feet
 1 kilometer = 10 hectometers = 3,280.8 feet

Liquid Measure

1 centiliter = 10 milliliters = .34 fl. ounce
 1 deciliter = 10 centiliters = 3.38 fl. ounces
 1 liter = 10 deciliters = 33.81 fl. ounces
 1 dekaliter = 10 liters = 2.64 gallons
 1 hectoliter = 10 dekaliters = 26.42 gallons
 1 kiloliter = 10 hectoliters = 264.18 gallons

Weights

1 centigram = 10 milligrams = .15 grain
 1 decigram = 10 centigrams = 1.54 grains
 1 gram = 10 decigram = .035 ounce
 1 dekagram = 10 grams = .35 ounce
 1 hectogram = 10 dekagrams = 3.52 ounces
 1 kilogram = 10 hectograms = 2.2 pounds
 1 quintal = 100 kilograms = 220.46 pounds
 1 metric ton = 10 quintals = 1.1 short tons

Square Measure

1 sq. centimeter = 100 sq. millimeters = .155 sq. inch
 1 sq. decimeter = 100 sq. centimeters = 15.5 sq. inches
 1 sq. meter (centare) = 100 sq. decimeters = 10.76 sq. feet
 1 sq. dekameter (are) = 100 sq. meters = 1,076.4 sq. feet
 1 sq. hectometer (hectare) = 100 sq. dekameters = 2.47 acres
 1 sq. kilometer = 100 sq. hectometers = .386 sq. mile

Cubic Measure

1 cu. centimeter = 1000 cu. millimeters = .06 cu. inch
 1 cu. decimeter = 1000 cu. centimeters = 61.02 cu. inches
 1 cu. meter = 1000 cu. decimeters = 35.31 cu. feet

Approximate Conversion Factors

<i>To change</i>	<i>To</i>	<i>Multiply by</i>	<i>To change</i>	<i>To</i>	<i>Multiply by</i>
inches	centimeters	2.540	ounce-inches	newton-meters	.007062
feet	meters	.305	centimeters	inches	.394
yards	meters	.914	meters	feet	3.280
miles	kilometers	1.609	meters	yards	1.094
square inches	square centimeters	6.451	kilometers	miles	.621
square feet	square meters	.983	square centimeters	square inches	.155
square yards	square meters	.836	square meters	square feet	10.764
square miles	square kilometers	2.590	square meters	square yards	1.196
acres	square hectometers	.405	square kilometers	square miles	.386
cubic feet	cubic meters	.028	square hectometers	acres	2.471
cubic yards	cubic meters	.765	cubic meters	cubic feet	35.315
fluid ounces	milliliters	29.573	cubic meters	cubic yards	1.308
pints	liters	.473	milliliters	fluid ounces	.034
quarts	liters	.946	liters	pints	2.113
gallons	liters	3.785	liters	quarts	1.057
ounces	grams	28.349	liters	gallons	.264
pounds	kilograms	.454	grams	ounces	.035
short tons	metric tons	.907	kilograms	pounds	2.205
pound-foot	newton-meters	1.356	metric tons	short tons	1.102
pound-inches	newton meters	.11296			

Temperature (Exact)

°F	Fahrenheit temperature	5/9 (after subtracting 32)	Celsius temperature	°C
----	------------------------	----------------------------	---------------------	----

